

Additive Manufacturing Journal

The international journal for research & development on
Additive Manufacturing & 3D Printing Technologies

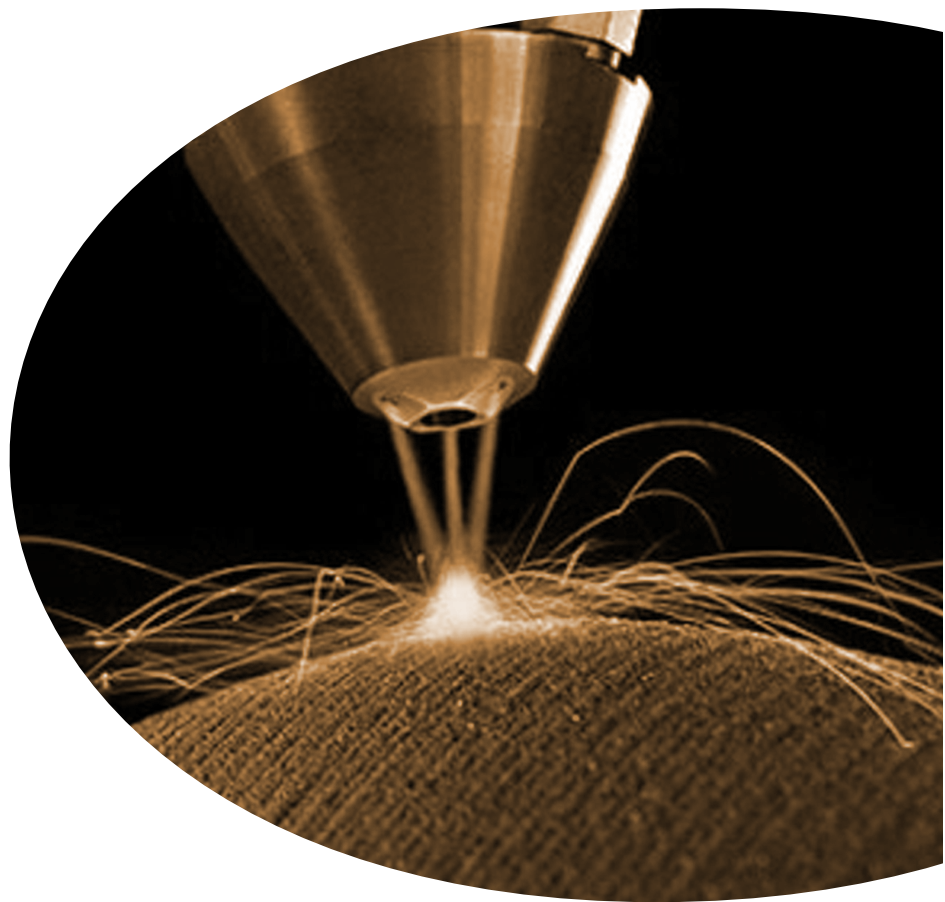

Additive Manufacturing Journal

ISSN 2395 - 4221

© 2015 Additive Manufacturing Society of India

EDITORIAL BOARD

Editor-in-Chief

Dr. Pulak M Pandey

Indian Institute of Technology, Delhi, India

Prof. David Ian Wimpenny

Manufacturing Technology Centre, Coventry, UK

Dr. Ravi Kumar Dwivedi

Maulana Azad National Institute of Technology, Bhopal, India

Managing Editor

L. Jyothish Kumar

Additive Manufacturing Society of India, Bangalore, India

Associate Editor

Prof. Keshavamurthy D.B.

Additive Manufacturing Society of India, Bangalore, India

Editorial Board

Dr. David Bourell,

Temple Foundation Professor – Aerospace, Mech & Manufacture Engineering Department. University of Texas Austin, USA

Dr. Khalid Abdelghany

Director, Central Metallurgical Research & Development Institute (CMRDI), Egypt

Dr. Suman Das

Director, Direct Digital Manufacturing Laboratory, Georgia Institute of Technology, USA

Prof. Alain Bernard

Vice President, French Rapid Prototyping Association

Dr. C. S. Kumar

Professor, Indian Institute of Technology, Kharagpur, India

Dr. Bahram Asiabanpour

Director of Rapid Product and Process Development Research Center Texas State University, USA

Dr. K. P. Raju Rajurkar

Director, Center for Nontraditional Manufacturing Research, University of Nebraska, Lincoln, USA

Dr. Ehsan Toyserkani

Director of Multi-Scale Additive Manufacturing Lab University of Waterloo, Canada.

Dr. Wan Abdul Rahman

Director, Advanced Manufacturing Technology Centre, SIRIM, Malaysia

Dr. Sarat Singamneni

Associate Professor, AUT University, Auckland, New Zealand

Mission Statement :

Additive Manufacturing Journal provides our Researchers, academic & industrialists with useful information regarding research & development of additive manufacturing & 3D printing Technologies. A Peer review process ensures the content's quality and relevance.

About Additive Manufacturing Journal

Additive Manufacturing Society of India (AMSI) is a professional body with the objective to promote 3D printing & Additive Manufacturing Technologies. AMSI helps the design, research and development organizations, manufacturing professionals and academics in 3D Printing, Additive Manufacturing and allied technologies.

AMSI is the publisher of International Journal on Additive Manufacturing technologies. The journal is dedicated to 3D printing and Additive Manufacturing technologies and peer reviewed by experts. The journal aims to benefit the researchers and authors in emerging 3D printing and additive manufacturing technology.

This journal is also available online at :

journal Information

issuu.com/amsiindia/docs/am_journal

Online journal content available worldwide at :

www.issuu.com

Contents

- 01 Access this journal online
- 02 **Editorial**
- 03 **Mathematical Modeling for Surface Hardness in FDM Assisted Vacuum Moulding of Al-SiC Metal Matrix Composite**
Sanjeev Kumar, Rupinder Singh
- 11 **Novel Image-Based Lattice Generation Techniques**
Yash Agarwal, David Raymont
- 14 **3D Finite Element Analysis of Selective Laser Melting Process**
Kurian Antony
- 18 **Effective and efficient additive manufacturing ecosystems**
Aniruddha Srinath, Saurabh Dubey
- 24 **Reverse Engineering & 3d Printing of Medical, A&D Components**
Ravi Katukam
- 28 **Influence of Reinforcement Shape on Flexural Properties of Additive Manufactured Multi Material Polymer Structure**
Vijayanand. R, Sugavaneswaran. M, Arumaikkannu. G
- 33 **Development of low cost surface finishing equipment for surface finish enhancement in 3D Printed Parts**
Sreekanth N V, Arjun C C, Dr. K Guruprasad

Editorial

It is my immense pleasure to invite you and read the inaugural issue of the 'Additive Manufacturing Journal' published by Additive Manufacturing Society of India.

This international journal will provide a platform and unparalleled opportunity for scientists, researchers and academicians to involve and contribute to the development of cutting edge additive manufacturing technology research.

The 'Additive Manufacturing Journal' addresses an urgent need for a high quality, peer reviewed journal, which addresses the entire spectrum of 3D printing and Additive Manufacturing research and innovation such as;

- Materials development
- Machinery and process innovation
- Design for Additive Manufacturing
- Part finishing
- Inspection technology for complex Additive Manufactured components.

Bringing together all of this information in a single publication provides a researchers with a key resource to support their work and moreover an ideal place to publish the result of their trials.

I hope the research work featured in 'Additive Manufacturing Journal' will be fruitful to the readers and will set up many new milestones.

Prof.David Wimpenny

Mathematical Modeling for Surface Hardness in FDM Assisted Vacuum Moulding of Al-SiC Metal Matrix Composite

Sanjeev Kumar[#], Rupinder Singh^{*}

[#]Mechanical Engineering Department, PEC Univ. of Technology, Chandigarh-160012, India

^{*}Production Engineering Dept., G.N.D.E. College, Ludhiana-141006, Punjab, India

[#]skthakkarpec@yahoo.com ^{*}rupindersingh78@yahoo.com

Abstract— Al-SiC metal matrix composites (MMC) have many potential engineering applications. Not much work hitherto has been reported for modeling the surface hardness (SH) of Al-SiC MMC fabricated by fused deposition modeling assisted vacuum moulding (VM). In the present study, patterns made by the FDM process were used to fabricate components of the MMC. VM is one of the casting processes, which is distinctly different from other sand casting processes as this process requires no binders for holding the sand grains together in the mould. Any shape or size can be produced in a VM from thin walls to thick sections, or from castings weighing ounces to several tons. Fine surface finish and excellent dimensional accuracy, no moisture related defects, no cost for binders, excellent sand permeability, and no toxic fumes from burning of the binders are key advantages of VM. The percentage of SiC in the composite was varied from 5% to 10% and its effect on surface hardness was studied. Three input parameters, namely, chemical composition, component volume and slurry grit size were selected to give output in the form of SH. Outcome of the Taguchi model was used for developing a mathematical model for SH; using Buckingham's π -theorem for Al-SiC MMC. For validation of this model, final observations were made under both experimental conditions (based upon Taguchi design) and theoretically developed mathematical equations. Comparison of SH results obtained experimentally agree very well with predictions through mathematical equations. The verification experiment revealed that on an average there is 7% improvement in SH. The radiographic image of the casting surface obtained at the optimized process conditions revealed no surface defects. Hence, it may be concluded that the improvement in surface hardness has been achieved without sacrificing the quality of the casting. It is expected that this study will help in estimating the main effects of these process variables on SH and will shed light on the hardness mechanism in VM of Al-SiC Composites.

Keywords— Al-SiC metal matrix composite, vacuum moulding, surface hardness, Buckingham's π -theorem, Fused deposition modeling

I. INTRODUCTION

Fused deposition modeling (FDM), being an additive manufacturing (AM) technology, is most commonly used for modelling, prototyping and production applications in aerospace, automobile, textile sectors etc. FDM has been established as one of the commercial AM technology by which cost-effective physical objects are created directly from CAD data [1]. In working, FDM employs the principle of "additive" which means to add the material rather than the

subtraction. This principle helps in producing the components in very less time, cost and also resulted into very less amount of material wastage. Fig. 1 shows schematic of FDM. The models or patterns prepared with FDM are generally made up of Acrylonitrile-Butadiene-Styrene (ABS) material. Now day's these FDM patterns are being used for casting with well established process called vacuum moulding (VM) process. VM process is also known as green process because it uses natural silica sand which is dry (so reduces the problem of mullers & mixers) and un-bonded (eliminate formation of fumes on pouring molten metal). It is one of the casting processes, which is distinctly different from other sand casting processes as this process requires no binders for holding the sand grains together in the mould [2]. The vacuum inside the mould results in a net pressure pushing in, holding the sand rigidly in the shape of the pattern, even after the pattern is removed. The process uses a specially designed, strong, highly flexible polymer film to seal the open ends of the sand mould and form the mould cavity [3].

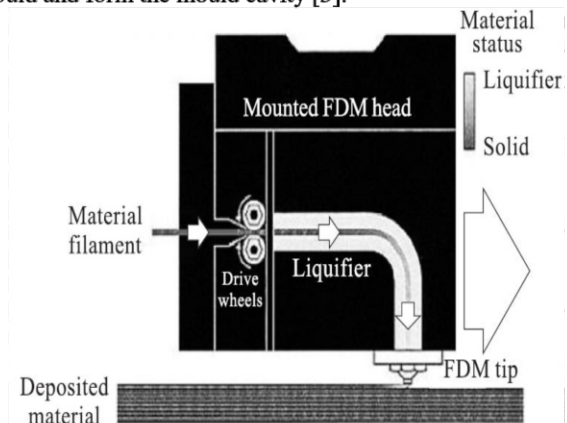

Fig. 1 Schematics of FDM machine [1]

The Al-SiC, MMC is engineered combination of the metal (Al) and hard particle/ceramic (SiC) to get tailored properties [4]. These are also in use for the space shuttle, commercial airliners, electronic substrates, bicycles, automobiles, golf clubs, and a variety of other applications [5]. Many researchers have proposed different methods for Al-SiC, MMC development (like powder metallurgy, stir casting etc.) [6]. The literature review reveals that lot of work has been

reported on optimization of VM process [7-9]. Further it has been reported that there has been a critical need for development of cost effective Al-SiC MMC [10-13]. Some researchers have highlighted the various process parameters (like: vacuum imposed, vibration frequency, pouring temperature and plastic film thickness) for the sound casting produced by VM process. But hitherto no work has been reported for modeling the SH in VM of Al-SiC MMC prepared by using FDM based pattern on FDM. So, the present investigation has been focused to develop mathematical model for SH in VM of Al-SiC MMC. For VM of Al-SiC MMC, an approach to model SH was proposed and applied [14]. This model was an attempt for predicting the SH as macro model in VM and is based upon robust design concept of Taguchi technique. The model was mechanistic in sense that parameters can be observed experimentally from a few experiments for a particular material and then used in prediction of SH over a wide range of process parameters. This was demonstrated for Al-SiC MMC, where very good predictions were obtained using an estimate of multi parameters at a time. In that study, effects of three process parameters (component volume; vacuum pressure; and chemical composition) were revealed. Table I shows various input and output parameters used in experimental study.

TABLE I

VARIOUS INPUT AND OUTPUT PARAMETERS

Input parameters	Output parameters
1. Three component volume levels (42411.50, 57726.76, 75398.22 mm ³) 2. Three levels of vacuum pressure (0.04, 0.05 and 0.06 N/mm ²) 3. Three levels of composition (Al-5% SiC, Al-7.5% SiC Al-10% SiC)	SH

The relationships were studied by considering interaction between these variables. Table II and III shows control log of experimentation (based upon Taguchi L9 O.A) and experimental observations for SH.

TABLE III

CONTROL LOG OF EXPERIMENTATION

S. No.	Volume (mm ³)	Vacuum pressure (N/mm ²)	Composition
1	42411.50	0.04	Al-5%SiC
2	42411.50	0.05	Al-7.5%SiC
3	42411.50	0.06	Al-10%SiC
4	57726.76	0.04	Al-7.5%SiC
5	57726.76	0.05	Al-10%SiC
6	57726.76	0.06	Al-5%SiC
7	75398.22	0.04	Al-10%SiC
8	75398.22	0.05	Al-5%SiC
9	75398.22	0.06	Al-7.5%SiC

TABLE IV

EXPERIMENTAL OBSERVATIONS FOR SH

S. No.	Volume ³ (mm)	Vacuum Pressure ² (N/mm)	Composition	Micro hardness (HV)		
				H1	H2	H3
1	42411.50	0.04	Al-5%SiC	58	57	55
2	42411.50	0.05	Al-7.5%SiC	120	115	117
3	42411.50	0.06	Al-10%SiC	128	120	122
4	57726.76	0.04	Al-5%SiC	61	58	55
5	57726.76	0.05	Al-7.5%SiC	152	150	145
6	57726.76	0.06	Al-10%SiC	136	130	128
7	75398.22	0.04	Al-5%SiC	115	110	108
8	75398.22	0.05	Al-7.5%SiC	173	165	167
9	75398.22	0.06	Al-10%SiC	161	155	157

On the basis of this model, Singh and Singh [14] studied the relationships between SH and controllable process parameters. These relationships agree well with the trends observed by experimental observations made otherwise [4-8].

A. Description of the VM process

Fig. 2 and 3 respectively shows steps in VM process and 3D view of VM setup. A pattern is placed on hollow carrier plate. In this process hollow carrier plate is a vacuum chamber connected with surge tank by hose pipes. Plastic film having thickness range from (0.076 to 0.20 mm) was softened by

heating. After heating, softened plastic film drapes over the pattern. By the application of 0.04N/mm^2 vacuum pressure, acting through the pattern vents to draw it tightly around the pattern. Now the first mould box is placed on the film-coated pattern. First mould box is filled with dry un-bonded silica sand. Slight vibration compacts the silica sand to maximum bulk density. After that sprue cup is formed and the mould surface leveled. Then the back of the mould is covered with unheated plastic film. After this the vacuum pressure is applied to the first mould box and closes the vacuum valve of hollow carrier plate. The atmospheric pressure hardens the silica sand. The mould strips easily when the vacuum pressure is released on the pattern carrier plate. After that second mould box is prepared and placed on the first mould box. Then it is also filled with dry un-bonded silica sand. After that sand gets hard by the application of vacuum pressure. Proper gating is provided in the second mould box through which molten metal enters into cavity. During pouring, molds are kept under vacuum pressure because the plastic vaporizes but the vacuum pressure keeps the shape of the sand while the metal solidifies. After cooling the vacuum pressure is released and free-flowing sand drop away leaving a clean casting, with no sand lumps.

VM process can be limited to as few as five items (namely: vacuum system, Film heater, vibrating table, pattern carrier and flasks) for automation or for higher production [10]. There is no need for heavy, noisy jolt squeeze equipment, ramming of slingers. Any shape or size can be produced in a VM from thin walls to thick sections, or from castings weighing ounces to several tons. Fine surface finish and excellent dimensional accuracy, no moisture related defects, no cost for binders, excellent sand permeability, and no toxic fumes from burning the binders are key advantages of VM. Based upon pilot experimentation and reported literature [9], the major VM process variables (namely: component volume, grain fineness number, pouring temperature, vacuum pressure, workpiece (W/P) hardness and frequency of vibrations induced) affecting SH are shown as cause and effect diagram (Ref. Fig. 4). The study presented in this paper is based on a previously published macro model based on Taguchi robust design [14]. The parameters like AFS No. 70 /grain size (0.210mm), frequency of vibration (30Hz) and pouring temperature ($750 \pm 20^\circ\text{C}$) was kept constant for present study. Table IV shows S/N ratio for SH and Figs. 5-7 shows variation of S/N ratio and micro hardness v/s volume, vacuum pressure and composition respectively.

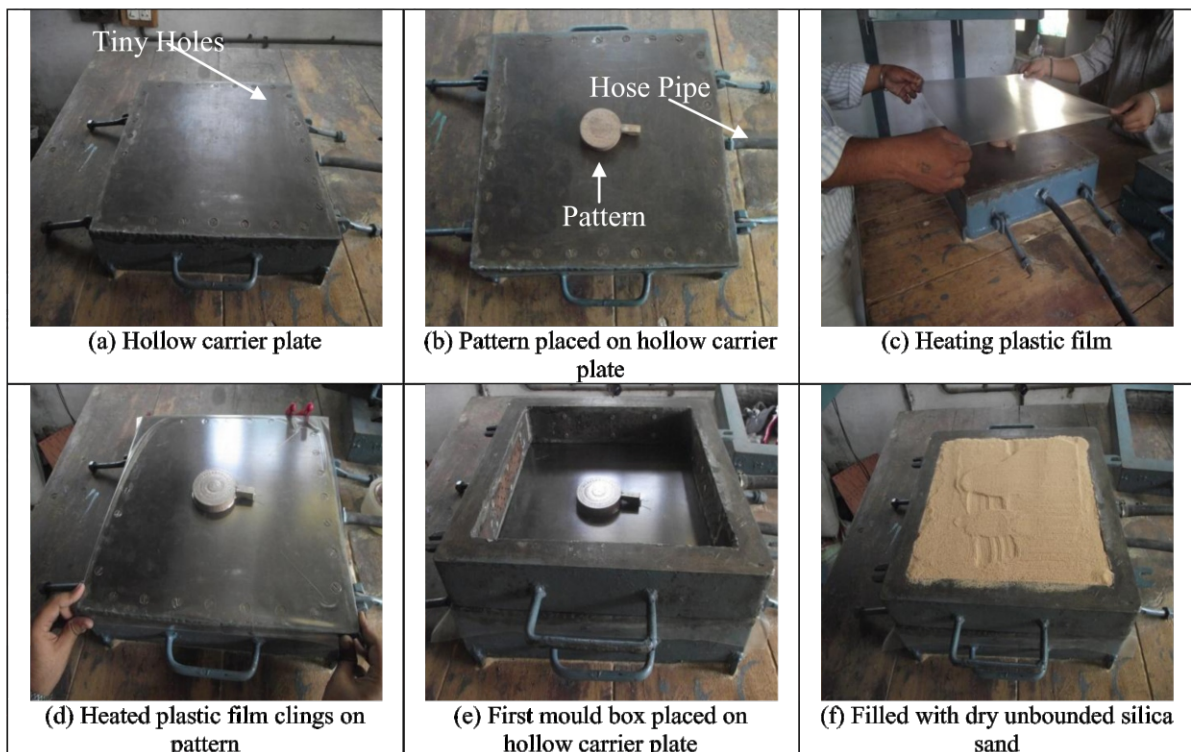

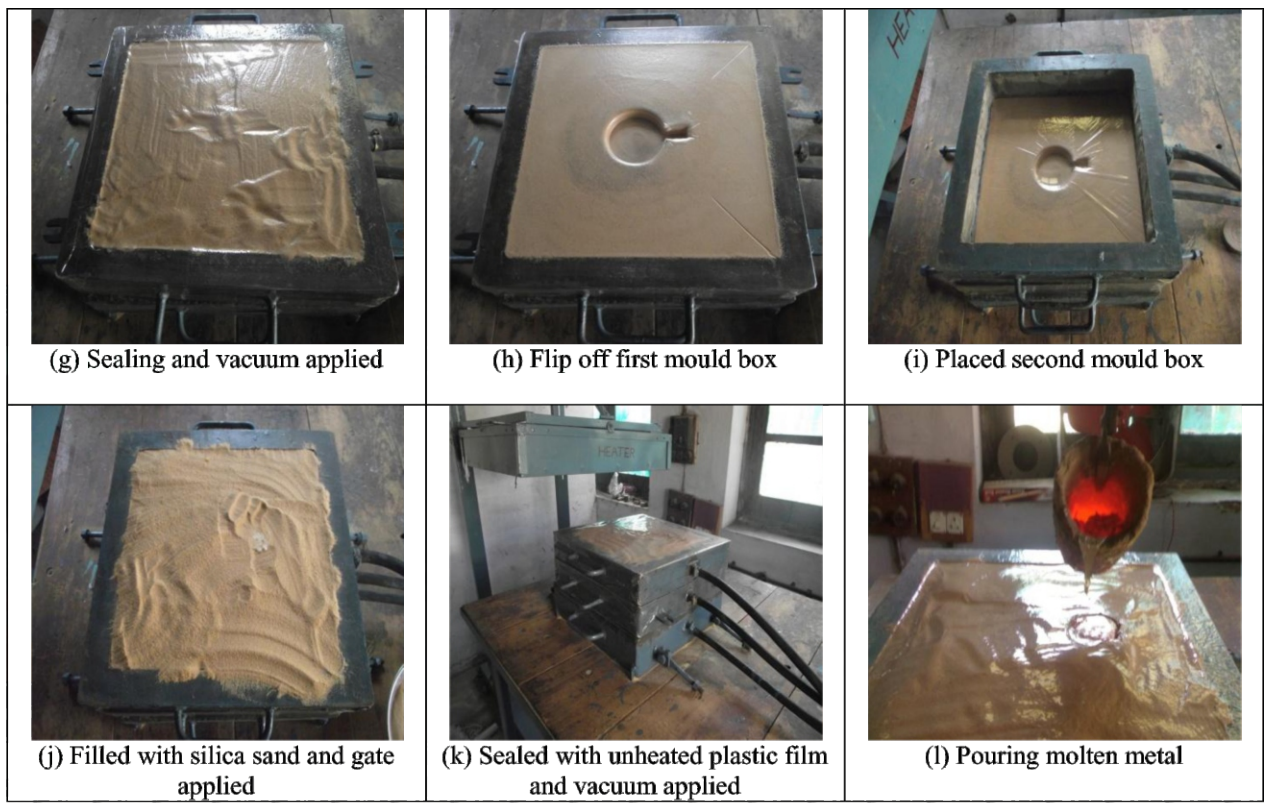

Fig. 2 Steps in VM process



Fig. 3 3D view of VM setup

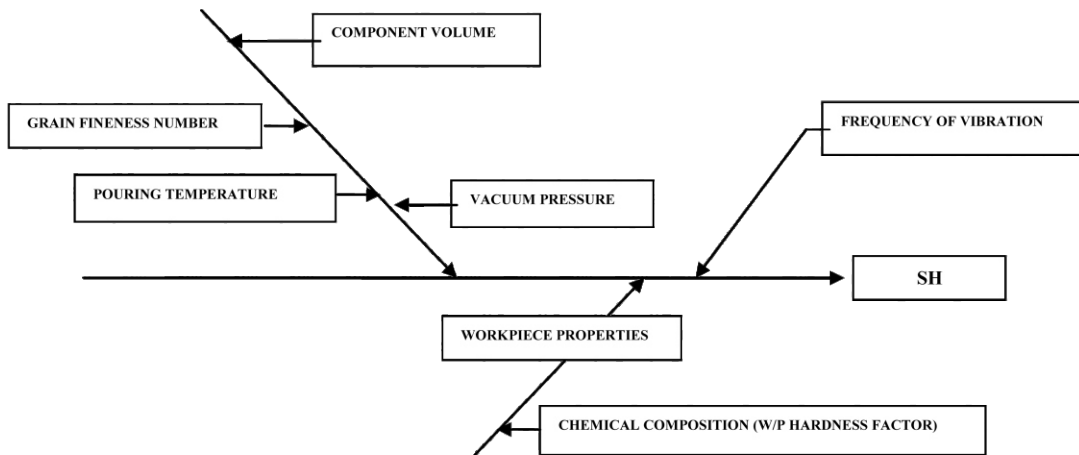

Fig. 4 Cause and effect diagram of SH

TABLE VIII
S/N RATIO FOR SH

R1	R2	R3	Sum Square	S/N ratio	Average
58	57	55	0.000312	35.06017	56.66667
120	115	117	7.27×10^{-5}	41.38445	117.3333
128	120	122	6.59×10^{-5}	41.8119	123.3333
61	58	55	0.000299	35.24528	58
152	150	145	4.51×10^{-5}	43.45857	149
136	130	128	5.81×10^{-5}	42.35892	131.3333
115	110	108	8.13×10^{-5}	40.89744	111
173	165	167	3.53×10^{-5}	44.51816	168.3333
161	155	157	4.03×10^{-5}	43.95156	157.6667

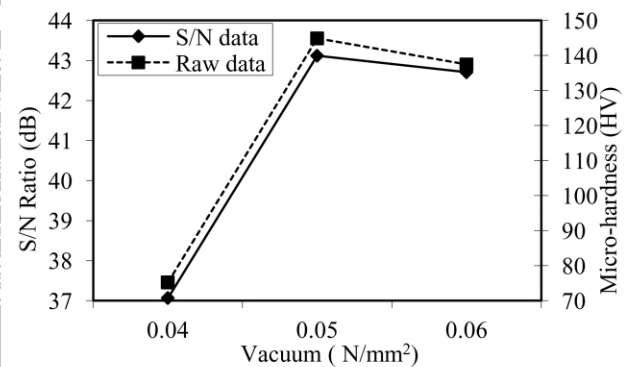

Fig. 6 Variation of S/N ratio and micro hardness v/s Vacuum pressure

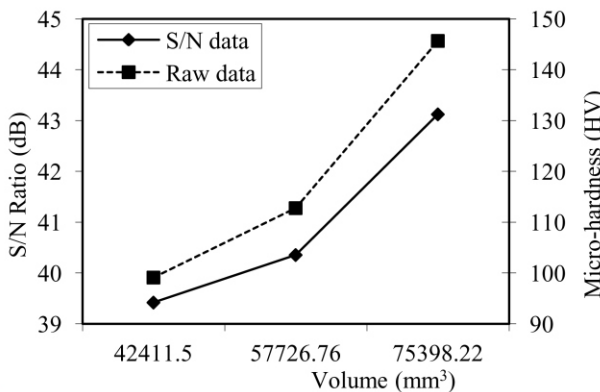

Fig. 5 Variation of S/N ratio and micro hardness v/s volume

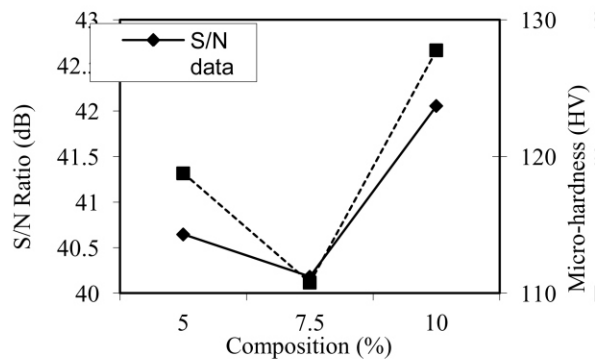

Fig. 7 Variation of S/N ratio and micro hardness v/s Composition

Now based upon geometric model, Buckingham's π -theorem has been used to study the relationships between SH

and controllable process parameters. There are three sections in this paper. Following this introduction, Section II describes mathematical modeling of SH. Conclusions have been drawn up in Section III, followed by references.

II. MATHEMATICAL MODELING OF SH

As per Taguchi design SH in VM was significantly dependent on chemical composition and component volume. Table V and VI respectively shows percentage contribution of input parameters and geometric model for SH [14]. The case study under consideration deals primarily with obtaining optimum system configuration in terms of response parameters with minimum expenditure of experimental resources. The best settings of control factors have been determined through experiments.

TABLE V
PERCENTAGE CONTRIBUTION FOR SH

Parameters	Sum of square	Percentage contribution
Volume	22.25383	22.6651
Vacuum	68.6142	69.88226
Composition	5.660818	5.765436
Error	1.656584	1.6872

TABLE VI
GEOMETRIC MODEL FOR SH [14]

OPTIMIZED SH CONDITIONS	
Volume	75398.22 mm ³
Vacuum	0.05 N/mm ²
Composition	Al-10% SiC

The Buckingham’s π-theorem proves that, in a physical problem including “n” quantities in which there are “m” dimensions, the quantities can be arranged in to “n-m” independent dimensionless parameters. In this approach dimensional analysis is used for developing the relations [15-16].

Since SH, ‘H’ depends upon three input parameters namely volume, vacuum pressure, grit size of moulding sand more significantly and rest three input parameters namely chemical composition, pouring temperature, frequency of vibration were not significant. Therefore by selecting basic dimensions:

- M (mass);
- L (length);
- T (time); and
- θ (temperature)

The dimensions of foregoing quantities would then be:-

1. The SH “H” (kgf/mm²) Vickers hardness $M L^{-1} T^{-2}$
2. Grain fineness number “N” (μm) L
3. Component volume “V” (mm³) L³
4. Chemical composition (W/P hardness factor) “C” (kgf/mm²) Vickers hardness $M L^{-1} T^{-2}$
5. Pouring Temperature “θ” (°C) θ
6. Vacuum pressure “P” (kgf/mm²) $M L^{-1} T^{-2}$
7. Frequency of vibration “F” (1/sec) T⁻¹

Now, $H = f(N, P, V, \theta, C, F)$ **Eq. 1**

In this case n is 7 and m is 4. So, we can have (n-m = 3) π₁, π₂, and π₃ three dimensionless groups.

Taking H, V and P as the quantities which directly go in π₁, π₂ and π₃ respectively, it can be written as:

π₁ = H. (N)^{α₁}. (P)^{β₁}. (θ)^{γ₁}. (F)^{δ₁} **Eq. 2**

π₂ = C. (N)^{α₂}. (P)^{β₂}. (θ)^{γ₂}. (F)^{δ₂} **Eq. 3**

π₃ = V. (N)^{α₃}. (P)^{β₃}. (θ)^{γ₃}. (F)^{δ₃} **Eq. 4**

Substituting the dimensions of each quantity and equating to zero, the ultimate exponent of each basic dimension has been achieved, since the “π_is” are dimensionless groups. Thus α_i, β_i, γ_i, δ_i, where i= 1, 2, 3, can be solved.

Solving for π₁, we get

π₁ = (M L⁻¹T⁻²). (L)^{α₁}. (M L⁻¹T⁻²)^{β₁}. (θ)^{γ₁}. (T⁻¹)^{δ₁} **Eq. 5**

Here,

M: 1 + β₁ = 0

L: -1 + α₁ - β₁ = 0

T: -2 - 2β₁ - δ₁ = 0

θ: γ₁ = 0

Solving, we get:

α₁ = 0, β₁ = -1, γ₁ = 0, δ₁ = 0

Thus

π₁ = H. (N)⁰. (P)⁻¹. (θ)⁰. (F)⁰ **Eq. 6**

π₁ = H/P

Similarly we get:

π₂ = (M L⁻¹T⁻²). (L)^{α₂}. (M L⁻¹T⁻²)^{β₂}. (θ)^{γ₂}. (T⁻¹)^{δ₂} **Eq. 7**

Solving, we get:

π₂ = C/P **Eq. 8**

Similarly:

π₃ = (L³). (L)^{α₃}. (M L⁻¹T⁻²)^{β₃}. (θ)^{γ₃}. (T⁻¹)^{δ₃} **Eq. 9**

Here,

M: β₃ = 0

L: 3 + α₃ - β₃ = 0

T: -2β₃ - δ₃ = 0

θ: γ₃ = 0

Solving, we get:

α₃ = -3, β₃ = 0, γ₃ = 0, δ₃ = 0

Thus

π₃ = V. (N)⁻³ **Eq. 10**

The ultimate relationship can be assumed to be of the form

π_i = f(π_j, π_k) **Eq. 11**

Let’s assume i = 1, j = 2, k = 3 Then functional relationship is of the form

π₁ = f(π₂, π₃)

Or

H/P = f(C/P, V/N³)

It has been experimentally found that H directly goes with C [14]. This means composition of casting significantly affects the SH. Therefore casting hardness factor has been taken as representative for development of mathematical equation.

Thus the equation becomes

$$H = C \cdot f(V/N^3) \quad \text{Eq. 12}$$

$$H = C \cdot K1 \{V/N^3\} \quad \text{Eq. 13}$$

Here 'K1' represents correction factor.

Now by keeping C/N^3 fixed, experiments were performed for different values of V, to find out 'H' and 'K1' in Eq.13.

The actual experimental data for three different component volumes have been collected and plotted in Fig. 8.

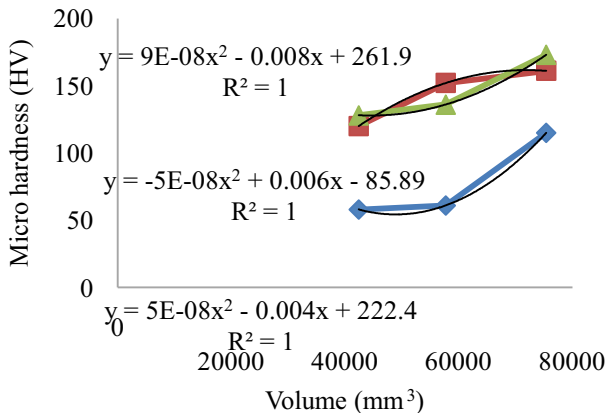

Fig. 8 SH Vs volume for different chemical compositions

The data collected has been further used for finding best fitting curve. The second degree polynomial equation comes out to be best fitted curve with coefficient of co-relation equals to "1". Thus equation 13 of SH for this case becomes:-

(For Al-5%SiC)

$$SH = C/N^3 \cdot (9 \times 10^{-8} \cdot V^2 - 0.0085V + 261.95) \quad \text{Eq. 14}$$

(For Al-7.5%SiC)

$$SH = C/N^3 \cdot (-5 \times 10^{-8} \cdot V^2 + 0.0069V - 85.892) \quad \text{Eq. 15}$$

(For Al-10%SiC)

$$SH = C/N^3 \cdot (5 \times 10^{-8} \cdot V^2 - 0.0042V + 222.48) \quad \text{Eq. 16}$$

Since this model is based upon Taguchi based model of SH, in which component volume and chemical composition are already optimized [14]. Therefore these parameters have not been varied while developing mathematical model. This model is useful in understanding effect of process parameters on SH in VM. The second degree polynomial equation has been used only to find best fit curve with coefficient of correlation close to 1.

Further to check the internal defects of the castings obtained the radiography analysis was done as per ASTM E 155 standard for gas holes and shrinkages at optimized conditions suggested by Taguchi design (Ref. Fig. 9). The

results obtained shows that the components prepared are acceptable in accordance with ASTM E155 standard.

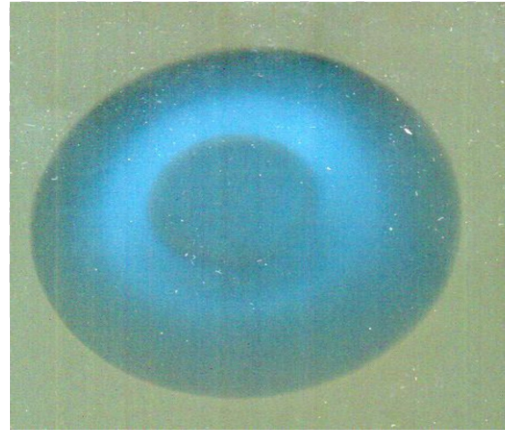

Fig. 9 Radiographic analysis of casting prepared by VM

The present results are valid for 90-95% confidence interval. For validation of this model, final observations were made under both experimental conditions (based upon Taguchi design) and theoretically developed mathematical equations. Comparison of SH result obtained experimentally agrees very well with predictions through mathematical equations. The verification experiment revealed that on an average there is 7% improvement in SH.

III. CONCLUSIONS

The Buckingham's π -theorem has been used for mathematical modeling of SH in VM process. The interactions among input parameters have been considered for developing the model. The following conclusions can be drawn from this study:

1. The contribution of input parameters to hardness of casting is: volume 22.55%, vacuum 2%, composition 70%. The mathematical equation developed here sufficiently express all significant input parameters (Ref. Eq. 14-16). As regard to mathematical model second degree polynomial equation for SH is giving best fitting curve with coefficient of co-relation ≈ 1 .
2. The verification experiment revealed that on an average there is 7% improvement in surface hardness, for selected workpiece. Also as regards to surface integrity of castings is concerned no surface defects have been observed in radiographic image at optimized machining conditions.

ACKNOWLEDGMENT

The authors would like to thank DST (Government of India) for financial support.

REFERENCES

- [1] M. Nikzad, S. H. Masood, I. Sbarski and A. Groth, "A study of melt flow analysis of ABS-Iron composite in fused deposition modelling process", *Tsinghua Science and Technology Journal*, vol. 14, issue S1, pp. 29-37, 2009.
- [2] S. I. Bakhtiyarov, R. Overfelt, M. G. Black and D.J. Weiss, "Design and V-Process Production of Cast Magnesium Component", *Transactions of the American Foundry men's Society Journal*, vol. 113, pp: 879 – 886, 2005.
- [3] P. B. Barua, P. Kumar and J. L. Gaindhar, "Quality of V- Process moulds through Taguchi's Technique" *International Journal of Quality and Reliability Engineering*, vol. 12, pp: 421–427, 1996.
- [4] D. Bishop and S. Bose, "Mechanical Properties of V-Process Molded Steel Castings", *Transactions of the American Foundry men's Society Journal*, vol. 91, pp: 441-446, 1983.
- [5] J. L. Gaindhar, C. K. Jain and K. Subbarathnanmaiah, "Effect of Sand Variables on Dimensional Accuracy of Al-4% Cu Alloy Castings Produced by V-Process" *Transactions of the American Foundry men's Society Journal*, vol. 93, pp: 303-306, 1985.
- [6] P. R. Gouwens, "Vacuum Molding (The V-Process) Perspective and into the Future", *Transactions of the American Foundry men's Society Journal*, vol. 98, pp:174, 2005.
- [7] C. K. Jain and J. L. Gaindhar, "Simulating Behavior of Sand under Vacuum in V-Process", *Transaction of American Foundry men's Society Journal*, vol. 94, pp: 86-107, 1986.
- [8] P. Kumar and R. C. Creese, "Effect of Zircon Sand (added to silica sand) Surface Finish of Al-11% SiC V-Process", *Transactions of the American Foundry men's Society Journal*, vol. 107, pp: 95-98, 1999.
- [9] P. Kumar, and R. C. Creese, "Effect of Fly Ash Addition on Mechanical Properties of Al-11% Si Alloy Castings Produced by V-Process", *Transactions of the American Foundry men's Society Journal*, vol. 109 pp: 1-15, 2001.
- [10] P. Kumar and J. L. Gaindhar, "Off-line Quality Control for V-Process Castings", *Quality and Reliability Engineering International Journal*, vol. 11, pp: 175–181, 1995.
- [11] P. Kumar and J. L. Gaindhar, "Solidification Time and Mechanical Properties of Al-11%Si Alloy V-Processed Castings", *Transactions of the American Foundry men's Society Journal*, vol. 104, pp: 635-638, 2002.
- [12] P. Kumar, N. Singh and P. Goel, "A Multi-Objective Framework for the Design of Vacuum Sealed Molding Process", *Robotics and Computer Integrated Manufacturing*, vol.15, pp: 413-422, 1999.
- [13] S. Kumar, P. Kumar and H. S. Shan, "Effect of Process Parameters on the Solidification Time of Al-7% Si Alloy Castings Produced by VAEPC Process", *Materials and Manufacturing Processes*, vol. 22, pp: 879-886, 2007.
- [14] R. Singh and J. Singh, "Experimental investigations for development of MMC with vacuum moulding", *International journal of materials science and engineering*, vol. 2, issue 1, pp: 115-119, 2011.
- [15] R. Singh and J. S. Khamba, "Mathematical modeling of tool wear rate in ultrasonic machining of titanium", *The International Journal of Advanced Manufacturing Technology*, vol. 43, issue 5-6, pp: 573-580, 2009.
- [16] R. Singh and J. S. Khamba, "Mathematical modeling of surface roughness in ultrasonic machining of titanium using Buckingham- Π approach: A Review", *International Journal. of Abrasive Technology*, vol. 2, issue 1, pp: 3-24, 2009.

Novel Image-Based Lattice Generation Techniques

Yash Agarwal[#], David Raymont^{*}

[#]109A Adarsh Nagar, 305002, Ajmer, India

^{*}Simpleware Ltd., Bradninch Hall, Castle St, Exeter, Devon, EX4 3PL, UK

¹y.agarwal@simpleware.com ²d.raymont@simpleware.com

Abstract— Replacing the internal volume of CAD and image-based models with a lattice structure reduces weight without compromising functionality, and has many applications to aerospace and other industries. This paper discusses novel image-based lattice generation techniques for Additive Manufacturing processes, including its benefits and implementation within software.

Keywords— Additive Manufacturing, Lattices, Finite Element Analysis, Aerospace, Selective Laser Melting (SLM)

I. INTRODUCTION

Cellular lattice structures can be used to replace the volume of CAD and image-based parts, reducing weight but maintaining mechanical performance. However, adding lattices to parts using traditional CAD methods for Additive Manufacturing (AM) techniques such as Selective Laser Melting (SLM) can be difficult. This paper presents an alternative approach using image-based methods to generate implicitly defined periodic lattice structures suitable for AM and finite element analysis (FEA).

II. BACKGROUND

CAD techniques for creating lattice structures tend to be problematic when reproducing complex ‘ideal’ micro-architectures, particularly when multiple Boolean operations are involved. Previous efforts to create robust lattices in CAD have included using hybrid geometric modelling [1] and slicing bounding geometry [2], as well as geometry capture using periodic implicit functions [3].

The main challenge for these techniques involve functional grading of lattice structures and controlling precision factors such as minimum and maximum volume fractions when replacing the internal structure of a part. It can also be a challenge to produce appropriate, robust algorithms to generate triangulated surfaces for export to AM processes, particularly when designing support structures for parts and metallic lattice structures. Moreover, the process of ‘hollowing’ out a CAD part and replacing it with a lattice structure can cause problems with cavities in the final model.

III. IMAGE-BASED SOLUTION

Methods have been developed by Simpleware Ltd. (Exeter, UK) for generating robust lattice structures that can be added to parts and used to reduce weight and optimise designs prior to printing. Lattice structures are created using implicit surfaces, defined as an iso-surface of some function f , providing a compact representation for complex surfaces that

are flexible to modify and enable well-defined Boolean operations.

A. Lattice generation

The Simpleware approach produces lattices by generating image volumes that represent implicit functions so that both volume and surface meshes can be constructed; this involves using a process known as voxelisation to convert a CAD object into an image. A volume is generated using greyscale values, and the Marching Cubes algorithm is then used to create a robust triangulated surface; the reconstructed surface is placed as close as possible to an ‘ideal’ surface [4].

Converting a CAD geometry into image data creates an intermediate step in lattice creation and integration with parts that enables a high degree of flexibility for customising properties. Different types of unit cell structures can be selected, including Schwartz and Schoen variants, and Neovius’ surfaces; different volume fractions and other metrics can be used depending on requirements.

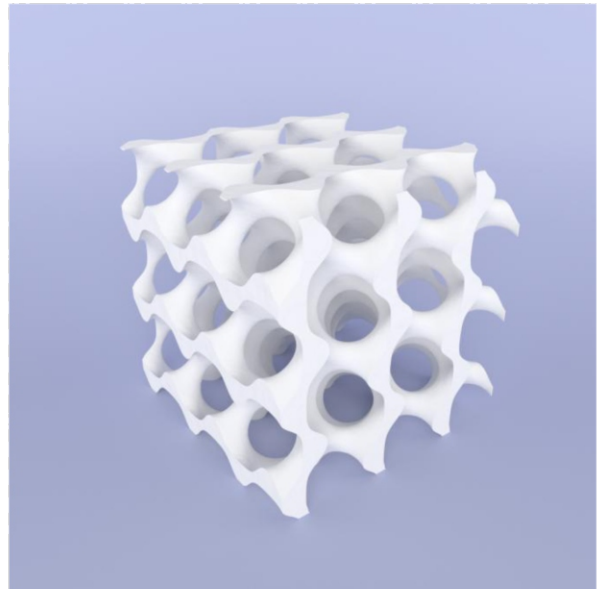

Fig. 1 Example of a Schoen Gyroid lattice structure

B. Lattice/CAD Integration

Lattices can be integrated with CAD parts within Simpleware software to create watertight models that maintain exterior geometries, enabling the hollowing out of a volume to a specified wall thickness. Techniques have also been developed by Simpleware to automatically close any cavities created during the hollowing process, with unique capabilities

to generate blended junctions between lattice and enclosing walls. By using an image-based approach, it is possible to manipulate the lattice and the final mechanical properties of a part before it is exported as an STL or other file to Additive Manufacturing or 3D printing processes [5].

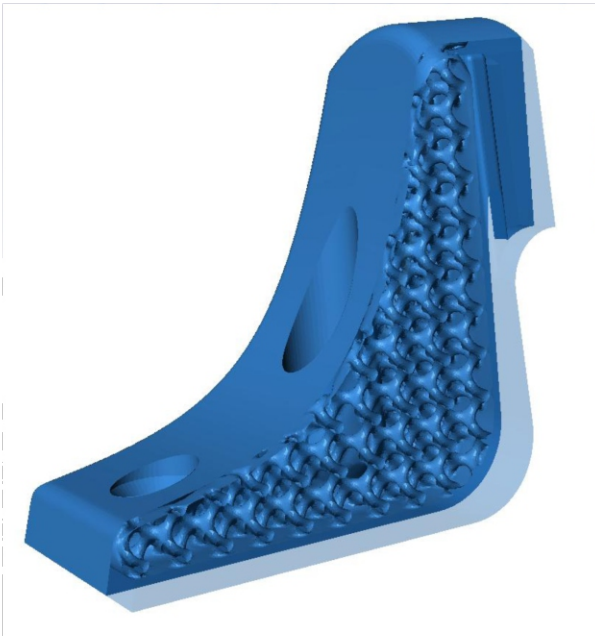

Fig. 2 Internal lattice placed within a part

C. Finite Element Analysis

Researchers and engineers wanting to evaluate the performance of a part with a lattice before prototyping can use physics-based simulation as a lower-cost alternative to experimental tests. A straightforward method has been developed to generate a finite element (FE) mesh of a part with a lattice, with multiple options to tailor the size, material properties and other metrics within the software [6]. Meshes can be prepared for specific finite element and computational fluid dynamics (CFD) solvers. One of the benefits of working with image-based models and lattices involves being able to mesh specific regions of interest. A cavity region can, for example, be meshed to enable computational fluid dynamics studies.

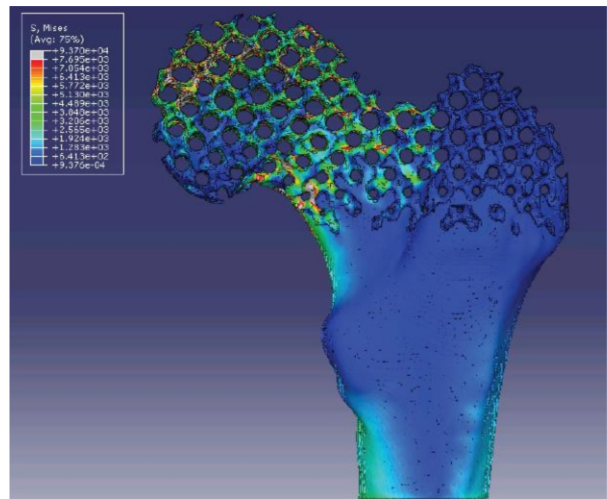

Fig. 3 Example of a meshed model with lattice

D. Applications

Image-based lattice techniques have been used by Simpleware and other partners for several past and ongoing research and development projects funded by the UK's Technology Strategy Board (now Innovate UK). This has included the SAVING project (Sustainable product development via design optimization and Additive manufacturing (2009-2012) [7]. The SAVING project focused on generating efficient periodic lattice structures for manufacturing, with the goal of redesigning conventional parts to save weight. Specific applications included adding a lattice to a brake calliper hanger, reducing its volume by 51% for printing as a titanium alloy; the resulting design demonstrated the same strength and deflection as the original machined part, despite being 18% lighter [8].

More recently, the same techniques have been used in the Innovate UK-funded LIGHT (Inspired new design freedoms and LIGHTweight solutions for metal additive manufacturing), particularly for exploring the potential of lightweighting for aerospace, automotive and other parts [9].

IV. CONCLUSIONS

Image-based lattice generation techniques developed for commercial software applications provide engineers and researchers with a wide range of options for customising a lattice and a surrounding part without affecting its exterior geometry. The use of these proprietary techniques allow CAD parts to be worked on in image space and meshed, resulting in watertight export files for AM. The future applications of this technology are therefore significant, from aerospace and automotive prototyping to investigating new material structures for medical implant designs.

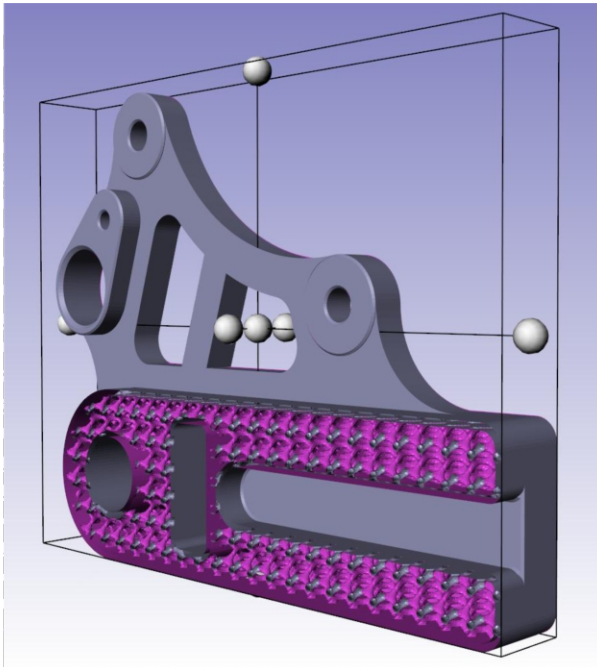

Fig. 4 Lattice within a brake calliper

ACKNOWLEDGMENT

Funding for research carried out in the SAVING Project was provided by the Technology Strategy Board (now Innovate UK) under TP14/SMP/6/I/BA036D. Other project partners included Plunkett Associates, 3T RPD, Delcam, Crucible, EOS and the University of Exeter.

The LIGHT project is supported by Innovate UK, which has the simple aim to accelerate economic growth by stimulating and supporting business-led innovation. Other

partners in the project include Bloodhound SSC, HiETA, CRDM/3DSsystems, EOS, Magna Parva and Delcam.

REFERENCES

- [1] H. Wang, Y. Chen, and D.W. Rosen, "A hybrid geometric modeling method for large scale conforming cellular structures," *ASME Conference Proceedings*, 2005, pp. 421-427.
- [2] B. Starly, "Biomimetic Design and Fabrication of Tissue Engineered Scaffolds Using Computer Aided Tissue Engineering," Ph.D thesis, Department of Mechanical Engineering and Mechanics, Drexel University, 2006.
- [3] R. Gabrielli, "Foam geometry and structural design of porous material," Ph.D thesis, Department of Mechanical Engineering, University of Bath, 2009.
- [4] P.G. Young and D. Raymont, "Image processing method and method of three-dimensional printing incorporating the same," U.S. Patent 8 874 248, Oct. 28, 2014.
- [5] (2015) Simpleware website. [Online]. Available: <http://simpleware.com/services/stls-for-3d-printing.html>
- [6] P.G. Young, T.B.H. Beresford-West, S.R.L. Coward, B. Notarberardino, B. Walker, A. Abdul-Aziz, "An efficient approach to converting 3D image data into highly accurate computational models," *Philosophical Transactions of the Royal Society*, 366, pp. 3155-3173, 2008.
- [7] (2015) The Saving Project website. [Online]. Available: <http://www.manufacturingthefuture.co.uk/>
- [8] Plunkett Associates (2002) Racing bike weight reduced with DMLS. [Online]. Available: http://www.manufacturingthefuture.co.uk/_resources/casestudies/TSB-CaliperHanger.pdf
- [9] (2015) The LIGHT Project website. [Online]. Available: <http://www.light-project.co.uk/>

3D Finite Element Analysis of Selective Laser Melting Process

Kurian Antony

Department of Mechanical Engineering,
Amal Jyothi College of Engineering, Kanjirappally, Kerala, India 686518,
kurianantony@amaljyothi.ac.in
Telephone Number:+91 9544827944,
Fax: +91 4828 251136.

Abstract— The laser melting process is used to manufacture metallic parts directly from metallic powders. There are several issues concerned with laser melting of metallic powders. Thermal distortion is one among the serious problems in laser melting process. The main cause of thermal distortion is due to the uncontrolled temperature distribution in the metallic powder layer. Therefore the study of temperature distribution within the metallic powder layer during laser melting process is important for producing better quality product. In this paper a transient thermal model with finite element method has been developed to calculate the temperature distribution in SS316L powder layer. A finite element code has been developed and the obtained result of temperature distribution depicts the temperature gradient along X- and Y-axis.

Keywords— Selective Laser Melting, FEA Analysis, Heat Transfer Model, SS316L,

I. INTRODUCTION

Thermal distortion of the part is one of the limitations of laser melting process, which may lead to undesired shrinkage and cracks [1, 2]. The processing parameters such as laser power, scanning speed, laser spot size, and scanning strategy all play a crucial role on the development of temperature gradients and residual stresses in the part which can leads to thermal distortion [2, 3]. These parameters are usually optimized through experimental means for specific machines and materials. The detailed investigation of all different parameters and materials for laser melting through experiments can be more time consuming and costly. Therefore, these issues can be addressed by implementing numerical methods as a tool to study the role of these parameters on temperature distribution [4]. For predicting the temperature and stress fields in laser melting process, the finite element method is the most commonly used numerical method. Childs et al. [5] investigated the influence of process parameters on the single layers in laser melting process and found that melted powder increased with increasing scanning speed. The effect of layer thickness on the laser melted parts was investigated by Zaeh and Branner [6].

Matsumoto et al. [7] developed a finite element method for single layer parts on SLM. Ma and Bin [8] proposed a 3D FEA model with fixed temperature heat source for calculating the evolution of temperature and thermal stresses within a single metallic layer formed on the powder bed using two different scanning patterns in SLM. It was found that the distortion and transient stresses of a layer processed by a moving laser beam decreased with fractal scanning pattern.

In this study, a three dimensional non-linear transient finite element model based on sequentially coupled thermo-mechanical field analysis was developed in ANSYS to predict the temperature distribution on the powder bed. Simulation of the moving heat source and changing boundary conditions are accomplished by a user written subroutine implemented in ANSYS parametric design language. Since the laser heat energy is transported well below powder bed in SLM, the laser energy density was applied as a volumetric heat source rather than a surface heat flux. Temperature dependent physical properties of 316L stainless steel powder material are taken into account and latent heat of fusion is considered. Table 1 summarizes the parameters used in the finite element simulation.

Table. 1 FEA simulation parameters.

<i>Parameter</i>	<i>Value</i>
<i>Laser power, P</i>	150 W
<i>Scanning speed, V</i>	12 m/min
<i>Spot diameter, D</i>	300 μm
<i>Powder bed thickness, T</i>	100 μm
<i>Mesh Type</i>	Hexahedral

2. Thermal modelling

The following classical 3D heat conduction equation given by [9].

$$\rho c \frac{\partial T}{\partial t} = \frac{\partial}{\partial x} \left(k \frac{\partial T}{\partial x} \right) + \frac{\partial}{\partial y} \left(k \frac{\partial T}{\partial y} \right) + \frac{\partial}{\partial z} \left(k \frac{\partial T}{\partial z} \right) + Q$$

Where ρ is the material density (kg/m^3); c is the specific heat capacity (J/kg K); T is the temperature; t is the interaction time; k is thermal conductivity (W/m K); and $Q = (x, y, z, t)$ is the volumetric heat generation (W/m^3). The effective thermal conductivity is defined as a function of porosity of the metallic powder [10]. The porosity of the metallic powder Φ can be calculated as,

$$\phi = \frac{\rho_{\text{bulk}} - \rho_{\text{powder}}}{\rho_{\text{bulk}}}$$

where Φ is the porosity of the powder; ρ_{bulk} and ρ_{powder} are the densities of the bulk and powder materials. The porosity is assumed to vary from $\Phi = 0.4$ for powder state to $\Phi = 0$ at solid state. The thermal conductivity of the powder can be expressed as.

$$k_{\text{powder}} = k_{\text{bulk}}(1 - \phi)$$

Where k_{powder} and k_{bulk} are thermal conductivities of powder and the melted materials. The latent heat of fusion is incorporated in the simulation by an artificial increase in the liquid specific heat. The relationship between the enthalpy (H), density (ρ), and specific heat (c) can be written as,

$$H = \int \rho c(T) dT$$

2.1.1. Boundary conditions

The initial boundary condition of uniform temperature distribution throughout the powder bed prior to laser melting at time $t = 0$ can be applied as,

$$T(x, y, z, 0) = T_0(x, y, z)$$

T_0 is the ambient temperature as 300K. Laser axis direction at $z = 0$,

$$-k \left[\frac{\partial T}{\partial z} \right]_{z=0} = Q - h(T_0 - T_{\text{surf}})$$

Where 'h' is the heat transfer coefficient at the powder surface which is taken as (10 W/m K); and T_{surf} is the temperature of the powder bed surface.

Since the layers are built on powder bed with large thickness, the heat transfer at the bottom of the metal powder can be assumed negligible

$$\left[\frac{\partial T}{\partial z} \right]_{z=z_m} = 0 \text{ and } T_{z_m} = T_0$$

2.2. Heat source modelling

The most common Gaussian beam profile TEM00 shown in Fig. 1a and given by,

$$I = I_0 \exp\left(-\frac{2r^2}{\omega^2}\right)$$

where r is the radial distance from the beam centre; I_0 is the intensity of the beam at $r = 0$; and ω is the radius of the beam at which

$$I = I_0 e^{-2}$$

This can be written as,

$$I(r) = \frac{2AP}{\pi\omega^2} \exp\left(-\frac{2r^2}{\omega^2}\right)$$

A is the absorptivity of the powder material which can be calculated by knowing the reflectivity of the material k . Reflectivity of iron 0.7 was considered as such for stainless steel 316L.

3. Results and Discussions

Simulation results on three different time steps have been selected. At each time step the temperature distribution along the powder bed has been calculated. In laser melting process, due to the laser heat energy, the temperature distribution in the powder bed changes rapidly with respect to time and space. Fig. 1a shows the temperature at the beginning of the laser path, from which, the very high temperature gradients in the laser spot on the

powder bed due to an applied Gaussian TEM00 heat mode. The temperature of the powder particles is elevated rapidly due to the action of absorbed laser energy, causing a molten pool. Furthermore over heating of powder bed can even leads to evaporation of the powder materials. The temperature which predicted highest for the molten zone of the powder material is 3534 K for [P = 150 W, V = 12 m/min, D= 300 μ m] and exceeds the melting temperature of 316L stainless steel (1672 K). The decrease of maximum temperature can be attributed to the fact that when the conductivity of the solidified layer increases than that of the conductivity of the previously solidified regions of the track. At the second times step of 0.2 sec the maximum temperature attained by the powder is of 3537 K. The thermal gradient changes as the laser track and the melt pool moves along with the laser source. Further it is observed that the temperature gradient in the front side of the moving laser source is much higher than that in the rear side. The shape of the melt pool of powder bed resembles as a comet tail depicts in Fig. 1c. This trend of distorted temperature distribution towards the rear side of the laser melted specimens was also reported in other temperature simulations [11]. This can be attributed to the fact that the rapidly cooled laser melted material has greater conductive properties than the unmelted powder in front of the laser.

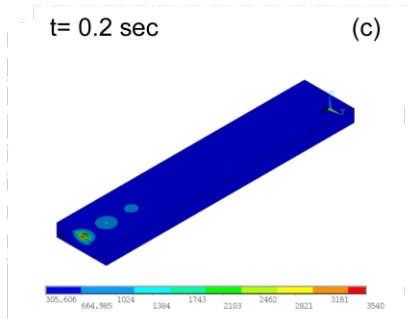
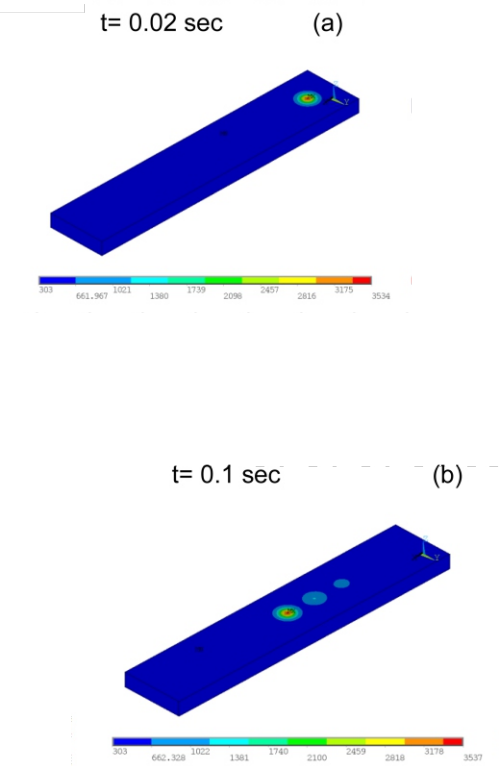

Fig. 1 (a-c) Temperature distribution at Power 150(watts); Laser speed 12 (m/min); Spot Diameter (300 μ m)

4. Conclusion

To predict the temperature fields in the laser melted powder bed, a three dimensional transient finite element models was developed. The FEA model results can be summarized as. The highest temperature gradient was reported as 3540 K. The numerical results reveal the intensity of the temperature in three different locations of the powder bed layer when exposed to higher laser power.

References

- [1] Kruth, J., Froyen, L., Van, Vaerenbergh, J., Mercelis, P., Rombouts, M., Lauwers, B., 2004, "Selective laser melting of iron-based powder", *J Mater Process Technol.*,149(1),pp.616–22.
- [2] Kurian, Antony., Arivazhagan, N., Senthilkumaran, K.,2014, "Studies on Wettability of Stainless Steel 316L powder in laser melting process",*J.Eng.Sci. Technol.*,9,5,2014 ISSN 1823-4690
- [3] Kurian, Antony., Arivazhagan, N., Senthilkumaran, K., 2013, "Influence of laser melting process parameters on surface roughness behavior for SS316L powder", *J. Corros. Sci. Eng.*,16, , ISSN 1466-8858.
- [4] Rohit T, Kurian Antony, N. Arivazhagan, K.Senthilkumaran, 2013, Studies on absorptivity and marangoni flow during laser melting. *Adv. Mater. Res.*, ,622, , 531-534, ISSN: 10226680
- [5] Childs, T., Hauser, C., Badrossamay, M., 2005, "Selective laser sintering (melting) of stainless and tool steel powders: experiments and modelling", *Proc Inst Mech Eng, Part B: J Eng Manuf*,219(4),p.339–57.
- [6] Zaeh, M., Branner, G., 2010, "Investigations on residual stresses and deformations in selective laser melting", *Prod Eng*;4(1):35–45.
- [7] Matsumoto, M., Shiomi, M., Osakada, K., Abe, F., 2004, "Finite element analysis of single layer forming on metallic powder bed in rapid prototyping by selective laser processing", *Int J Mach Tools Manuf*,42(1),p.61–7.
- [8] Ma, L., Bin, H., 2007, "Temperature and stress analysis and simulation in fractal scanning-based laser sintering", *Int J Adv Manuf Technol*,34(9),p.898–903.
- [9] Carslaw H, Jaeger J. *Conduction of heat in solids*, 2nd ed. vol. 1; 1959.
- [10] Dong, L., Makradi, A., Ahzi, S., Remond, Y., 2009, "Three-dimensional transient finite element analysis of the selective laser sintering process", *J Mater Process Technol*,29,p.700–6.
- [11] Shen, X,F., 2005, "Finite element simulation of thermal distribution in direct metal laser multi-track sintering" *J Sichuan Univ*,37(1),p.47–51.

Effective and efficient additive manufacturing ecosystems

¹[Aniruddha Srinath](mailto:Aniruddha.Srinath@cyient.com), ¹[Saurabh Dubey](mailto:Saurabh.Dubey@cyient.com)

¹ *Product Realization Group, Cyient Limited*

Aniruddha.Srinath@cyient.com

Saurabh.Dubey@cyient.com

Abstract- Additive Manufacturing, a technology which has been in existence since three decades is now successfully being transitioned from a research setting to finding technologically and financially viable end-user applications. In other words, Additive Manufacturing is climbing up in terms of maturity when viewed from Technology Readiness Levels. A key ingredient for organizations to establish successful business models around this technology are effective and efficient ecosystems. This paper looks at the critical ecosystem elements which are required to complete the additive manufacturing environment, from the perspective of a Global Engineering and Product Development Organization, like Cyient. The requirements for an additive manufacturing business are looked at, from a technical and economic perspective. The Additive Manufacturing Value Chain is decoded, and key elements of the value chain are identified. The requirements are then mapped to the elements of the value chain, and the dependency on each element is elaborated. A recommendation of activities which need to be outsourced and the ones which need to be retained in-house is also put forth. The feasibility of practicing open innovation in this advanced manufacturing ecosystem is examined.

Keywords— Additive Manufacturing, Ecosystem, Value Chain, Outsourcing considerations, Open Innovation

I. INTRODUCTION- BUSINESS ECOSYSTEMS

It has been widely accepted in the last two decades that modern economic systems can be compared to a great extent with their biological ecosystems. There are many attributes in parallel to economics of humans and the ways in which living beings lead their lives; competition, specialization of work, co-operation for mutual benefits, utilization of superior bargaining positions and adaptability. The reasons, enablers and controls of change are also parallel. However, we have seen that economic systems change much faster.

Business Ecosystem, as a term was first introduced by James F Moore in the 1990s in his paper (F.Moore, 1995) titled "Predators and Prey". In his paper, Moore used several ecological metaphors to explain business ecosystems. According to Moore, a business ecosystem is "an economic community supported by a foundation of interacting organizations and individuals – the organisms of the business world." Moore also defined a

business ecosystem as an "extended system of mutually supportive organizations; communities of customers, suppliers, lead producers, and other stakeholders, financing, trade associations, standard bodies, labor unions, governmental and quasigovernmental institutions, and other interested parties. These communities come together in a partially intentional, highly self-organizing, and even somewhat accidental manner. The first definition highlights interaction within a business ecosystem, while the second one emphasises decentralised decision-making and self-organisation. Although Moore claims that the word industry should be replaced with the word business ecosystem, it is apparent that Moore's business ecosystem is closer to the concepts of cluster and value network.

Business ecosystems are based on core capabilities, which are exploited in order to produce the core product. In addition to the core product, a customer receives "a total experience" which includes a variety of complementary offers. Manufacturing enterprises are also undergoing transformation from a pure product focus to that of a service model (Stefan Wiesner, 2013), which is vastly improving their problem solving capability.

II. ADDITIVE MANUFACTURING PROCESS CHAIN

Additive manufacturing is the official industry standard term (ASTM International, 2012) for all applications of the technology. It is defined as the process of joining materials to make objects from 3D model data, usually layer upon layer, as opposed to subtractive manufacturing methodologies.

The process used to obtain additive manufactured parts varies to a given extent, mainly based on the end application. However, a generic process (Dr. Ian Gibson, 2010) is as follows:

1. Conceptualization and CAD
2. Conversion to STL
3. Transfer and manipulation of STL file on AM machine
4. Machine setup
5. Build
6. Part removal and cleanup
7. Post-processing of part
8. Application

This definition is suitable for additive manufacturing as a process but needs further elaboration in the context of Big-M Manufacturing, where the enterprise is considered. To elaborate, Big-M refers to the entire Product Realization process whereas Little-M refers to a subset of this process, where materials are converted and assembled. A generic Additive Manufacturing Enterprise process chain is as follows:

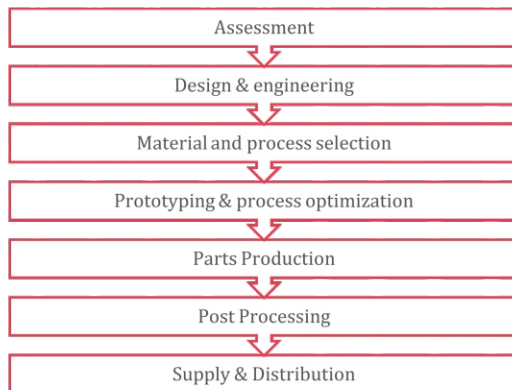

Table I: Additive Manufacturing Enterprise Process Chain

The elements of the Additive Manufacturing Enterprise Process chains are elaborated below:

1. **Assessment:** Though additive manufacturing provides the freedom to manufacture parts having the most complex design, it is not viable to produce all parts using this route. If it is more economical to make parts using conventional, subtractive manufacturing, that is recommended. Hence, it is imperative to conduct an assessment of part suitability for additive manufacturing. One thumb rule is to look for design complexity, low to medium production volumes and products with lots of moving parts in order to derive the maximum benefit.
2. **Design and Engineering:** The paradigm of design and engineering for additive manufacturing is hinged on two fulcrums (Dr. Ian Gibson, 2010):
 - The ability to design for complexity. In this respect, complexity covers complicated shapes, multiple structures, multiple materials and multiple functions in the same product.
 - Design and engineering to reduce costs and problems in manufacturing and assembly.
 Design efforts are mainly consolidated and carried out by three types of agencies: practitioners in industries like aerospace, organizations like ASTM which publish design guidelines and universities and other research organizations. There is an increasing impetus to make design rules and tools simplistic enough to be applied by customers and end users as well; an illustration is the increased use of medical additive manufacturing design software by surgeons to design and create implants unique and customized to patients.
3. **Material and Process Selection (Palmer, 2005):** With a myriad of companies all over the world involved in this disruptive technology, the customer has a problem of plenty to choose from, in terms of materials, processes, companies and even equipment. Optimization is required in terms of cost, schedule and quality, the order of priority often changing among the three parameters. There have been attempts to use computing power to provide consulting solutions but truly effective software, like the Cambridge Engineering Selector Suite for conventional manufacturing is yet to make its mark.
4. **Prototyping and process optimization:** This is a process (T.A Krol, 2013) carried out in order to validate the capability of the technology, process and the machine to achieve end-user defined functionality. As defined by Systems Engineering (International Council on Systems Engineering: SE Handbook Working Group, October 2011), prototyping could be used for functional, demonstration, qualification or operational testing. Based on the gap in intended and achieved results, process settings are optimized and materials are refined. The rapid characteristic of additive manufacturing helps here, for multiple iterations can be produced quickly and lessons learnt are quicker and more explicit and viewable.
5. **Parts Production:** It is unlikely that additive manufacturing will, in the near future, replace many conventional manufacturing methods like injection molding when it comes to high volumes, simply based on economies of scale. Its effectiveness is really in the vicinity of medium to low volume production (Eleonora Atzeni, 2012) (between 40~100 units). This phenomenon is reflecting in the origin, growth and success of service bureaus catering to additive manufacturing, which augment capabilities and capacities. It also merits to be highlighted that additive manufacturing was once touted to replace conventional manufacturing; nowadays, prevalent wisdom suggests that the two streams will co-exist and complement each other.
6. **Post Processing:** Post processing activities are often done in order to enhance the surface or strength properties of the part, remove any support material or to overcome a typical limitation of the additive manufacturing technology. Business reasons require that many times, the limitation of a particular additive technology be suppressed by extra post processing activities. Many products are also used as tools and patterns and they would typically require to be treated upon, using thermal or non-thermal techniques.
7. **Supply and distribution:** Additive Manufacturing is disrupting traditional supply chain and logistics activities with the ability to print parts just in time, reduce the number of parts needed in an assembly and hence their

movement as well as being close to the customer. However, organizations need to closely monitor the cost of shipping, which when amortized over fewer parts (for low volume production or prototypes) will result in a high cost per part, often making the cost of such shipping unattractive.

III. ADDITIVE MANUFACTURING VALUE CHAIN

A value chain, as opposed to a supply chain (which focuses on transactions) is based on the process view of organizations, with the manufacturing enterprise being the systems of systems (International Council on Systems Engineering: SE Handbook Working Group, October 2011), made up of subsystems which are systems by themselves and each with inputs, transformation processes and outputs. The end service or product always drives the value chain. Every link in the value chain determines the success of the whole, specifically in terms of the profits earned and costs incurred. Although Porter (Porter, 1985) distinguishes between primary and secondary activities, this paper considers all the links and identifies the key attributes required as well as the ecosystems required to fulfil every link in the value chain.

In this fast changing competitive environment, value (Richard Normann, 1993) is perceived very differently from conventional supply chains in the industrial economy where it was predominantly the positioning that a particular company took in its activities, covering industry, product and market segment. In the digital (and yet industrial!) economy, competition is replaced by co-opetition to form a system which perceives value from the eyes of the customer by continuously changing positions.

To strengthen the above statement, it was initially thought (Reeves, 2008) that additive manufacturing would disrupt traditional manufacturing supply chains, making huge plants and billions of dollars of investment redundant as well as resulting in lay-offs. The changed perception among students of this technology is that additive manufacturing will co-exist with traditional, subtractive manufacturing and the two will

complement each other, often co-located and also utilizing common infrastructure and skills and offering a unique set of value propositions to the customer as well as the company.

This change in mindset is also accompanied by a significant enhancement in the application of digital technologies related to software, data and connectivity in industrial manufacturing, leading to the genesis of the Digital Factory (Srinath, 2014). Manufacturing enterprises are more flexible, efficient, and able to resolve problems much quicker and delivery innovation quickly. This is because of the following:

- The extensive use of information and communication technologies like the internet of things and cloud technology.
- Increased use of mechatronics for more quick, accurate and reliable performance.
- A combination of Sensors for detection and measurement; actuators for movement and control.

The illustration below describes the key links in the Additive Manufacturing value chain as well as the attributes critical to the success of these links. These attributes can also be indicative of the infrastructure or skills required of every link, many of them involve the application of digital technologies. The table below describes these key attributes and their criticality in terms of the parameters which are usually tracker to gauge product or project success.

The stakeholders usually involved in each link are shown; it is implicit that roles of these stakeholders often overlap, due to the requirement of concurrence of activity. Though the links in the value chain are shown in a linear fashion, they are often iterative and recursive, and a lot of learning and correction happens from upstream to downstream and vice-versa. Another trend which can be observed is that upstream links are reflective of earlier levels of Technological readiness levels and downstream links production mirror TRLs which relate to application and commercialization of the product.

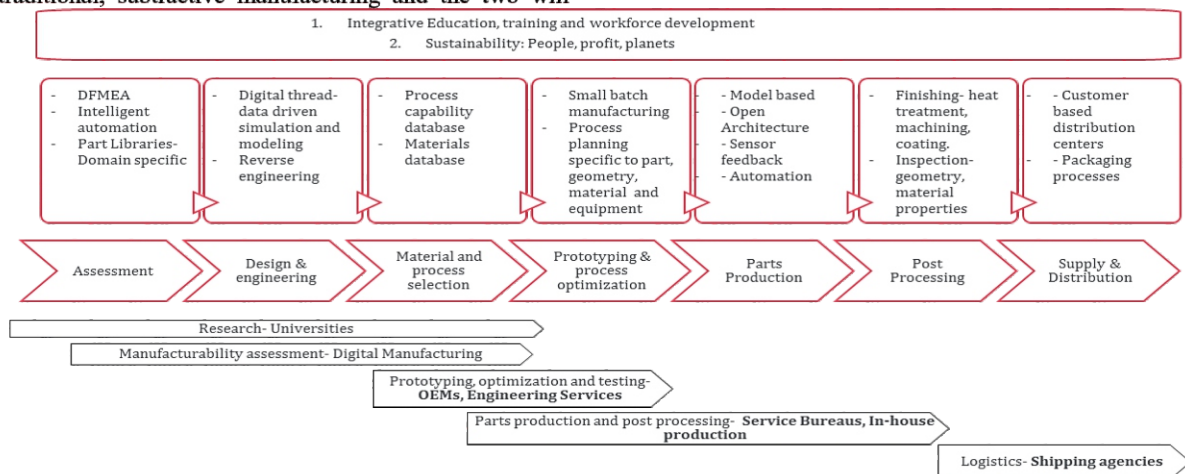

Figure 1: Additive Manufacturing Value Chain

Process	Activity	Description	Critical to Cost	Critical to Quality	Critical to Time
Assessment	Design failure mode effect analysis	Prediction of failure modes and effects for a part under focus	High	High	Medium
	Intelligent automation	Software which is able to predict the suitability of a typical part as a fit case for additive manufacturing.	High	High	Medium
	Domain Specific Part Libraries	A database of parts chosen as fit for additive manufacturing	High	High	High
Design and Engineering	Data driven simulation and modeling	Real time data streams are used for better analysis and prediction	Medium	Medium	High
	Reverse Engineering	Develop 3D models from existing products and derive details of cost and function in order to carry out value engineering and value analysis.	Medium	Medium	High
Material and Process Selection	Process Capability Database	Information about process capability, both internally and ecosystem.	Medium	Medium	High
	Materials library database	A database of standard and developed materials which serves as a ready reckoner for projects	Medium	Medium	High
Prototyping and Process Optimization	Small batch manufacturing	This is critical to support customer operations in an effective manner	High	Medium	High
	Process planning specific to part, geometry, material and equipment	Optimization of cost, quality and time	High	Medium	High
Parts Production	Model, open architecture based	Design complex products and improve human-machine interaction	Medium	Medium	High
	Sensor feedback	For establishing a control mechanism, which improves in-process quality	Medium	High	Low
	Process automation	For reduced human errors and minimizing human intervention	Low	High	High
Post Processing	Finishing-heat treatment, machining, coating	Often used to enhance product surface features and properties of strength and resistance to elements like corrosion.	Medium	Medium	Medium
	Inspection- geometry, material and properties	Capable to use both internally defined and customer specified inspection, Non-Destructive.	Low	High	Medium
Supply and Distribution	Customer based distribution centers	Distribution centers close to the customer, running on a glocal model	Medium	Medium	High
	Packaging processes	Safe and economical packaging for handling and transportation	Medium	Medium	Medium

Table II: Attributes of Additive Manufacturing Value Chain and their criticality

IV. IN-HOUSE VS. OUTSOURCING DECISIONS

Outsourcing of any product or activity is closely linked to the amount of de-specialization and hence commoditization it undergoes. What is presently considered advanced manufacturing will become ubiquitous and will be subject to harsh international competition, hence compelling the need for outsourcing partially or sometimes fully, the manufacturing activities. Some factors (Lucia Cusmano, 2007) which affect outsourcing decisions are quality, capacity, adherence to schedule, risk of disruption, discounting schemes, reliability and flexibility of the suppliers. Advanced manufacturing outsourcing further involves IP and its protection, ability to source smaller volumes in a cost-

effective manner, the ability to transfer technology and the learnability of the Supplier. Improved communication technologies have made the storage, encryption and transfer of data much easier, enabling even R&D organizations to monitor and control suppliers and their quality for critical activities. Outsourcing arrangements (Kaya, 2007) can be of various types, like risk/revenue sharing or profit and cost mechanisms. A checklist (University of Cambridge, 2007) of questions is used to determine whether an activity can be outsourced. Activities in the additive manufacturing supply chain can be positioned in the 2x2 quadrant below in terms of strategic importance and supplier effectiveness.

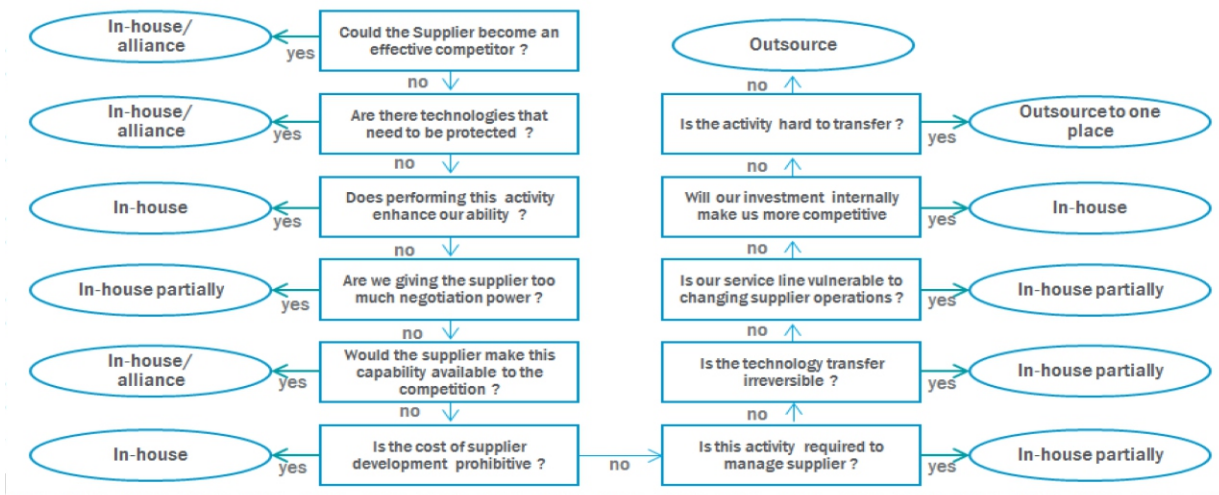

Figure 2: Outsourcing Decision Mechanism

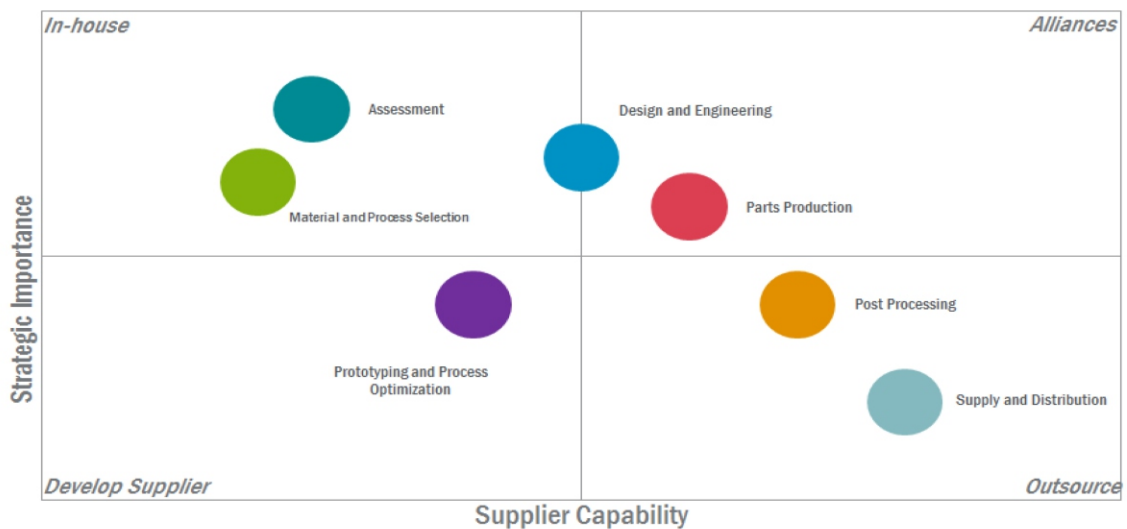

Figure 3 : Outsourcing Decision Quadrant

V. OPEN INNOVATION

A. Open Innovation Paradigm

Open Innovation is a new paradigm in business thinking, which suggests that companies look beyond their internal resources for access to knowledge and ideas, and involve partners in their efforts to create greater value for their customers as well as themselves. While this idea has been prevalent for some time, it was first articulated in its present form by Prof. Chesbrough (Chesbrough, 2011) of the University of California at Berkeley. Big companies like Xerox Parc, IBM and HP have been using this thinking to change the way they do business. Open innovation, calls for companies to make much greater use of external ideas and technologies while sharing their unused ideas with others. This requires each company to open up its business model to exchange ideas, knowledge and technology.

B. Open Innovation Business Model

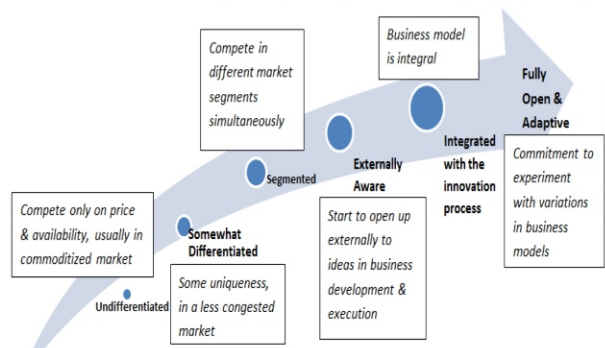

Figure 4: Open Innovation Business Model

A business model generally performs two important functions. First, it creates value by defining a series of

activities that ultimately delivers a product or service to end users. Second, it captures value by maintaining unique resources, assets, or positions within that series of activities, providing the seller a competitive advantage.

1. Reduced cost of conducting research and development	1. Possibility of revealing information not intended for sharing
2. Potential for improvement in development productivity	2. Potential for the hosting organization to lose their competitive advantage as a consequence of revealing intellectual property
3. Involvement of customers early in the development process	3. Increased complexity of controlling innovation and regulating how contributors affect a project
4. Increase in accuracy for market research and customer targeting	4. Devising a means to properly identify and incorporate external innovation
5. Potential for viral marketing.	5. Stretching strategies to extend beyond the firm in order to maximize the return from external innovation

Table III: Benefits and limitations of Open Innovation

C. Open Innovation Activities

1. **Platforming:** This approach involves developing and introducing a partially developed service, for the purpose of providing a framework or tool-kit for contributors to access, customize, and exploit.

2. **Idea competitions:** This model entails implementing a system that encourages competitiveness among contributors by rewarding successful submissions.

3. **Customer immersion:** While mostly orientated towards the end of the product development cycle, this technique involves extensive customer interaction through employees of the host organization.

4. **Collaborative design and development:** Similarly to product platforming, an organization incorporates its contributors into the development of the product but still controls and maintains the eventual products developed in collaboration with their contributors..

5. **Innovation networks:** An organization leverages a network of contributors in the design process by offering a reward in the form of an incentive.

ACKNOWLEDGEMENT

The authors wish to acknowledge our colleagues, customers and vendors at Cyient Limited who helped us obtain deep insights. A special thanks to Prof. Ian Gibson of Deakin University, a dinosaur of 3-D Printing!

REFERENCES

1. ASTM International. (2012). *Standard Terminology for Additive Manufacturing Technologies*. West Conshohocken, Pennsylvania, United States of America.
2. Chesbrough, H. (2011). *Open Services Innovation: Rethinking your business to compete and grow in a new era*. Haas School of Business, UC Berkeley.
3. Dr. Ian Gibson, D. D. (2010). *Additive Manufacturing Technologies: Rapid Prototyping to Direct Digital Manufacturing*. Springer US.

4. Eleonora Atzeni, A. S. (2012). Economics of additive manufacturing for end-user. *International journal of Advanced Manufacturing Technology*, 1147-1156.
5. F. Moore, J. (1995, May-June). Predators and Prey: A New Ecology of Competition. *Harvard Business Review*, p. 16.
6. International Council on Systems Engineering: SE Handbook Working Group. (October 2011). *Systems Engineering Handbook*. San Diego: International Council on Systems Engineering.
7. Kaya, O. (2007). *Outsourcing vs. In-House Production: A Comparison of Supply Chain Contracts with Effort Dependent Demand*. Koc University, Turkey.
8. Letizia Mortara, J. J. (2009). *How to implement open innovation: Lessons from studying large multinational companies*. Cambridge, UK: Center for Technology Management, Institute for Manufacturing.
9. Lucia Cusmano, M. L. (2007). *Globalisation of Production and Innovation*. Dynamics of Institutions and Markets in Europe.
10. Palmer, A. D. (2005). *The Design and Development of an Additive Fabrication Process and Material Selection Tool*. Orlando, Florida, United States of America: University of Central Florida.
11. Porter, M. (1985). *"Competitive Advantage"*. New York: The Free Press.
12. Reeves, P. (2008). How Rapid Manufacturing could transform supply chains. *CSCMP's Supply Chain (Quarterly)*.
13. Richard Normann, R. R. (1993, July-August). From Value Chain to Value Constellation: Designing Interactive Strategy. *Harvard Business Review*.
14. Srinath, A. (2014). *Internet of Things and Smart Manufacturing: Industry 4.0*. Bengaluru, Karnataka, India: Cyient Limited.
15. Stefan Wiesner, I. W.-D. (2013). *Manufacturing Service Ecosystems: Towards a New Model to Support Service Innovation Based on Extended Products*. *International Federation for Information Processing*, 305-313.
16. T.A Krol, C. M. (2013). Prioritization of Process Parameters for an Efficient Optimisation of Additive Manufacturing by Means of a Finite Element Method. *ScienceDirect*, 169-174.
17. University of Cambridge. (2007). *Making the Right things in the right places*. Cambridge: University of Cambridge Institute of Manufacturing.
18. University of Cambridge Institute for Manufacturing (IfM) and International Business Machines Corporation. (2008). *Succeeding through service innovation: A service perspective for education, research, business and government*. Cambridge, United Kingdom: University of Cambridge Institute of Manufacturing.

Reverse Engineering & 3d Printing of Medical, A&D Components

Ravi Katukam

Cyient Limited, Hyderabad
Ravi.Katukam@cyient.com

Abstract—

Additive manufacturing has brought the revolution the product design in various engineering disciplines. Current paper summarises few experiences of additive manufacturing for Medical, Aerospace & Defence products. Medical engineering has significantly benefitted from applying AM process for reverse engineering of medical devices. Reverse engineering of human face mask is taken up to understand the steps involved and to accelerate the processes of various steps from cloud data generation, polygon mesh, segmentation, parametric solid modelling and final CAD model making are successfully demonstrated on a human face like object. The surface texture is measured using CMM technology and compared with other published work. In Aerospace and Defence related product structural members of a micro air vehicle is printed using 3d printing. The component sizing is done such a way to meet the strength and deflection needs of a typical structural member. In addition a design optimization process is developed for 3d printed components. Error analysis and dimensional stability analysis of micro air vehicle parts are done and compared with CAD model and as produced model.

Keywords— Aerospace & Defence, Medical, Error Analysis, Reverse Engineering, CMM

I. INTRODUCTION

Additive manufacturing has been used extensively for building prototypes in various engineering domains. The ability to 3d print many materials including the metals enables engineer to accelerate the product design. One of the major applications of 3d printing is in reverse engineering and rapid prototyping.

- Mathematically possible shaped are possible to 3d print using the AM processes.
- The cost of making a prototype is less with AM processes.
- The ability to print intricate openings in structures
- Additive manufacturing helps to with less weight compared to conventional methods
- Am processes are being applied in Aerospace and Defence industry with certification from global bodies
- AM processes helps to get tailored properties as per the need of the component.

II. REVERSE ENGINEERING

An easy Reverse engineering is a modelling process from original data (which are often digitized from an object) that results in a concise geometric model exportable to CAD/CAM packages. The data points are digitized from the products, which may have been designed before CAD/CAM existed, produced by other manufacturers or made by hand (without CAD design at all). Nowadays, RE is changing from a tedious manual dimensioning or tracing process to a powerful engineering tool utilizing modern digitizing equipment and CAD/CAM systems. The first step in mechanical RE of a geometric model is data acquisition from a part by using some type of Digitizer. The two most commonly used digitizers are optical and mechanical. Considering the material of the finger joint bone, the required accuracy, the bone surface complexity and the speed requirement for this project, laser optical scanning is used for the digitizing process. Reverse engineering in this study involves the scanning of bone samples to determine the geometric range in which the models should fit into and form the basic surfaces to be used for the implants. Laser scanner was used to capture surface data points to create freeform surfaces of human bone samples. This was used to way to comply with the conference paper formatting requirements is to use this document as a template and simply type your text into it.

III. REVERSE ENGINEERING A FACE MASK

Medical application of RP was not developed to solve the problems of medical modelling [3]; it is more happenstance that it is suitable for such. It therefore follows that is not an ideal solution and there are problems in using it. The most obvious problem is cost. While it is difficult specifically to allocate cost to a process when considering the potential for saving or improving the quality of life, it is clear that all technologies have associated costs. Even where there are obvious benefits in terms of improving the medical service, the approach may be cost prohibitive. Many RP machines are costly to run, particularly in terms of material costs. This is partly a consequence of the relatively low number of machines currently available. As the technology becomes more popular in all areas, operating costs will surely drop. Indeed, evidence already shows that operating costs have

dropped consistently year on year over the last 15 years. In addition to cost, the properties of the materials used leave much to be desired. Most importantly, RP materials must be considerably more biocompatible than they are at present. Many materials are not even fit to be sterilized and taken into operating theatres. The mechanical properties of most RP parts are generally poor, with parts often being too weak or brittle to withstand constant use. One aim of RP research is to develop rapid manufacturing technologies that use the layer-based approach to direct manufacture of products. With the demanding environment that is associated with constant use, harsh and variable conditions and heavy physical loads, it is surely a long way off before rapid manufacture of medical devices is possible. The term refers to an alternative way of producing prototypes which required significantly more time and effort from skilled artisans. However, this is something engineers and product designers and developers can appreciate more than doctors and surgeons. A typical process flow for reverse engineering is explained in following picture.

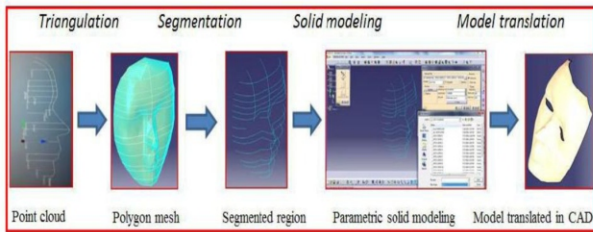

Fig.1. Typical process of Medical Reverse Engineering.

As it is, RP can only be applied to applications that involve planning over periods of weeks or months rather than emergency situations. Finally, doctors and surgeons are supported by many different technical experts. It is difficult to see exactly which type of technician would be responsible for making models, but it is likely such expertise is not commonly available in a normal hospital. This may have an influence on the type of machine that would prove suitable for medical applications since the more versatile machines also require greater care, attention and expertise in order to run successfully. A sample facemask is taken up for reverse engineering [1] using ABS material.

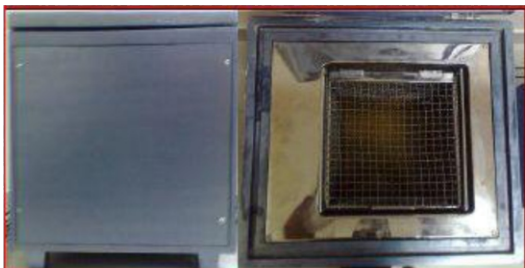

Fig.2. 3d printed human face like component

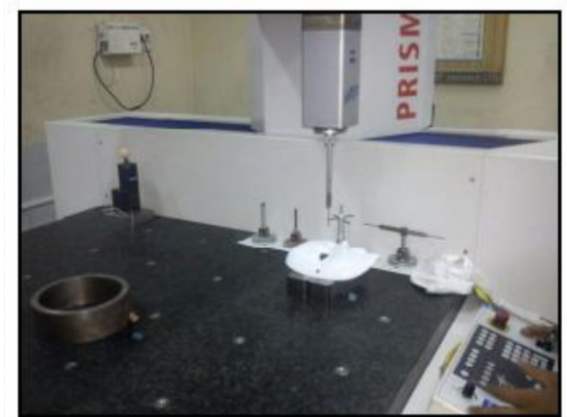

Fig.3. CMM Measurement of 3d printed object.

Following picture shows the CAD model and corresponding final printed part.

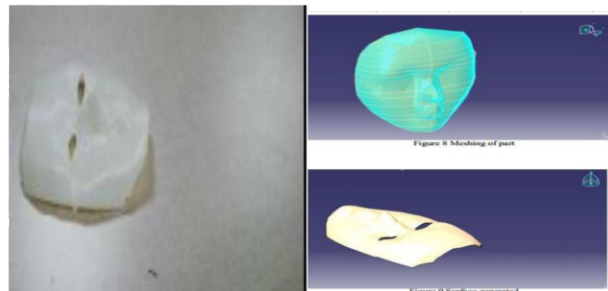

Fig.4. 3d printed human face like component

As technology inevitably charges forward, applications of RDM in medicine will expand. Research in biomaterials science indicates the feasibility of direct fabrication of implantable materials using RP-like technology. This could be an important advance allowing rapid manufacture of truly custom implantable devices such as joint prostheses, complete sections of missing bone or absorbablecaffolds that provide structure while engineered tissue replacements take hold. Instead of alloplastic materials, which are merely tolerated by the body, these newer materials have the potential to stimulate growth and actually be incorporated into the body. RP-generated models and treatment aides are for the most part manufactured by specialized service bureaus. Even with modern techniques for rapid data transfer via the internet and reliable overnight shipping there inevitably is a lead time of several days for service bureaus to Provide a model. As more specialties capitalize on rapid manufacturing, it may be cost effective for health care facilities to arrange for an on-site or nearby Rapid digital manufacture vendor. It is expected that, if the amount of time required to get a model or treatment device in the hands of a physician is reduced, they may find a wider acceptance, particularly in fields constrained by time

urgency such as orthopaedic trauma or cardiothoracic surgery. Computer power has increased exponentially over the last decade. Relatively inexpensive computers are now capable of handling the large amounts of data produced in medical imaging. Off-the-shelf graphics capabilities now produce fast renderings from image data and allow the construction of composite models built from multiple image datasets. Our research in increasing the accuracy of collecting the cloud data from which an accurate surface CAD model can be generated by means of minimum cost where every patient can afford and take the maximum credit of prostheses parts fits to their requirement. Although the cost of AM parts is high but our intension initially to work on human safety parts where the crash survivability in aircraft is very low when an unfortunate situation arises in sky. Therefore increasing the safety in aircraft with some head and neck arrangement for customized passengers who can afford the cost of the additive manufacturing parts to their own requirements.

IV. REVERSE ENGINEERING IN AERO & DEFENSE

The research on Micro Aerial Vehicles (MAV) is a comparably young field, which has emerged over the past few years. The ongoing miniaturization of electric components such as electric motors and the improvements in microelectronics made it possible to build miniature planes and helicopters at relatively low costs. This development also made it possible to start imitating insect and bird flight, which need a sophisticated miniaturized actuation chain for their flapping wing motion. The project is to come up with small aerial vehicles that can operate independently from ground stations, performing certain operations such as surveillance or measurement, especially in environments that are hardly accessible or even dangerous for people in future. One of the goals of research on Micro Air Vehicles (MAVs) is to arrive at fly-sized MAVs that can fly autonomously in complex environments such MAVs form a promise for observation tasks in places that are too small or too dangerous for humans to enter. Their small size would allow the MAVs to enter and navigate in narrow spaces, while autonomous flight would allow the MAV to operate at a large distance from its user. Essentially, there are two main approaches to creating small autonomous ornithopters: bottom-up and top-down. In the bottom-up approach, one starts by creating all the tiny parts that are deemed important to a fly-sized ornithopter. In the last few decades, small scale unmanned aerial vehicles (UAVs) have become more commonly used for many applications. The need for aircraft with greater maneuverability and hovering ability has led to current rise in quadcopter research. The four-rotor design allows quadcopters to be relatively simple in design yet highly reliable and maneuverable. Cutting-edge research is continuing to increase the viability of quadcopters by making advances in multi-craft communication, environment exploration, and maneuverability. If all of these developing qualities can be combined together, quadcopters would be capable of advanced autonomous missions that are currently not possible with any other vehicle. safety in aircraft with some head and neck arrangement for customized passengers who can afford the cost of the additive manufacturing parts to their own requirements

Results:

Distance	Distance (mm) (before printing)	Distance(mm) (After printing)	Deviation(mm)
dx1	30	29.9272	0.0728
dx2	64	63.08888	.09112
dx3	32	31.5444	.4556
Thickness (t)	2	1.8	.2

Fig.5. 3d printed error analysis

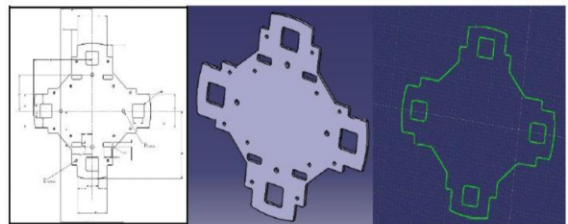

Fig.6. 3d printed part with cutouts

V. CONCLUSIONS

Technology inevitably charges forward, applications of RDM in medicine will expand. Research in biomaterials science indicates the feasibility of direct fabrication of implantable materials using RP-like technology. This could be an important advance allowing rapid manufacture of truly custom implantable devices such as joint prostheses, complete sections of missing bone or absorbable scaffolds that provide structure while engineered tissue replacements take hold. Instead of alloplastic materials, which are merely tolerated by the body, these newer materials have the potential to stimulate growth and actually be incorporated into the body. RP-generated models and treatment aides are for the most part manufactured by specialized service bureaus. Even with modern techniques for rapid data transfer via the internet and reliable overnight shipping there inevitably is a lead time of several days for service bureaus to provide a model. As more specialties capitalize on rapid manufacturing, it may be cost effective for health care facilities to arrange for an on-site or nearby Rapid digital manufacture vendor. It is expected that, if the amount of time required to get a model or treatment device in the hands of a physician is reduced, they may find a wider acceptance, particularly in fields constrained by time urgency such as orthopedic trauma or cardiothoracic surgery

Computer power has increased exponentially over the last decade. Relatively inexpensive computers are now capable

of handling the large amounts of data produced in medical imaging. Off-the-shelf graphics capabilities now produce fast renderings from image data and allow the construction of composite models built from multiple image datasets. Our research in increasing the accuracy of collecting the cloud data from which an accurate surface CAD model can be generated by means of minimum cost where every patient can afford and take the maximum credit of prostheses parts fits to their requirement. Although the cost of AM parts is high but our intension initially to work on human safety parts where the crash survivability in aircraft is very low when an unfortunate situation arises in sky. Therefore increasing the safety in aircraft with some head and neck arrangement for customized passengers who can afford the cost of the additive manufacturing parts to their own requirements

REFERENCES

- [1] Prakash Marripati, Ravi Katukam, Medical 3d Printing, Case Study, IJLET, Volume 5 issue 1 2015.
- [2] Lakshmikiran, Ravi Katukam, 3d printing of quad copter: A Case Study, International Journal of Latest Trends in Engineering and Technology (IJLET), Voll 2, Issue 2, 2015

Influence of Reinforcement Shape on Flexural Properties of Additive Manufactured Multi Material Polymer Structure

Vijayanand. R[#], Sugaveneswaran. M^{*}, Arumaikkannu. G^{*}

[#]*Department of Production Technology, MIT, Anna University, Chennai-600044, India.*

¹vijirboopathy@gmail.com

^{*}*Department of Manufacturing Engineering, CEG-Anna University, Chennai-600025, India.*

²sugaveneswaranm@gmail.com

³arumai@annauniv.edu

Abstract - Fabrication of polymer parts using additive manufacturing process has gained increasing interest because this process can built polymer parts or structures at a high resolution with complicated shapes and sub micron level feature sizes. However, strength of polymer parts fabricated through additive manufactured parts sometimes less when compared to parts fabricated through traditional manufacturing techniques. To increase the strength of polymer parts in terms of flexural property, inclusion of multi material is considered which is fabricated through Additive manufacturing process. So in this work, reinforcement in flat and corrugated shape (sine-wave ridged pattern) which is commonly found in nature and engineering structure in order to produce a compliant bending was employed in AM polymer parts to enhance its flexural properties. A series of 3-point bending tests over the multi material fabricated through polyjet 3DP process have been performed in order to investigate the inclusion of reinforcement (flat shape and corrugated shape) and without reinforcement material. Experimental results show that corrugated shape reinforcement has the ability to induce passive bending behaviour on AM multi material structures than flat shape reinforcement. Bending stiffness and strength between with and without reinforced material (with and without corrugated pattern) shows 2.72 times and 1.02 enhancements in flexural load and flexural strength respectively. Investigation over the influence of corrugated structure shows maximum flexural load withstanding of corrugated Pattern 2 is 50% higher than that of pattern 1, which may be advantageous for additive manufactured polymer parts employed in form, fit and functional applications when subjected to flexural load.

Key Words- 3D Printing, composite structure, corrugated structure, flexural strength, multi material structure.

I. INTRODUCTION

In Additive Manufacturing, 3-Dimensional objects/parts are fabricated directly from a computer model (Computer Aided Design (CAD) data), in which successive layers of materials were laid down according to computer control [1]. Because of addition

of materials layer by layer rapid prototyping is also referred as Additive Manufacturing (AM), the basic principle of this technology is that a model, initially generated using a three-dimensional Computer Aided Design (3D CAD) system, can be fabricated directly without the need for process planning. According to American Society for Testing Materials AM is defined (ASTM: F2792-12a) as “process of joining materials to make objects from 3D model data, usually layer by layer addition, in contrast to subtractive manufacturing methodologies, such as traditional manufacturing” [2]. Recent advancements in AM process have explored the possibility of fabrication of part with multi material or composite material structures [3&4]. From literature survey it was observed that few works were reported based upon employing AM technologies with multi material/composite material especially polymer based material in order to enhance the basic process, either to optimize the process or to improve the properties of the final part [5]. The reasons for applying Multi material strategies include [6]:

- Improving the mechanical properties of the AM polymer parts: Additional secondary materials may enhance the thermal or mechanical behaviour.
- Providing additional functionality to AM polymer parts: Due to additional material AM parts may have different colours with varying electrical conductivity.
- Improving the performance of the AM process: In these cases, additional material may be used as a barrier material that separates two regions, after removal of the secondary material, enables relative motion between the regions which helps in fabrication of complaint mechanism.

Above-mentioned purposes can be achieved either by presenting new materials or build strategies (e.g.,

software modifications) to the system. In other instances, the AM process construction (e.g., material delivery system) must be modified to include the new material [7]. But development of material delivery system is complex in terms of AM process machine construction and sometimes economically higher than software modifications. So the work presented here explores the use of CAD model (software modification strategies) for the purpose of representing multiple materials in composite material to the AM process. In addition, multi material harder constituent "reinforcement" in flat and corrugated shape (sine-wave ridged pattern as shown in Figure 1.) which is commonly found in nature and engineering structure in order to produce a compliant bending was employed to enhance the flexural properties of AM multi material structure [8]. Multi material structures are fabricated using polyjet 3DP technique. Flexural test over the fabricated multi material structure was done to understand the influence of flat shape and corrugated shape reinforcement.



Fig 1. Sine-Wave Rigid Corrugated Pattern for Enhancing Flexural Properties.

II. MODELLING OF MULTI MATERIAL STRUCTURE WITH CORRUGATED SHAPE

AM process take CAD model as input for machine instruction to move the controller and deposit the material where it is required [9]. But most of the CAD modelling software represents the part only with homogeneous material, which is difficult to represent multiple materials of composite materials. Furthermore, majority of AM process take CAD model in STL format as standard input. Since STL is a surface approximation only, there is no knowledge of the material representation. So for the purposes of

representing multiple materials for region to region, Boolean operation coupled with assembly operation were used to create CAD model with multiple material (one part for matrix and another part for reinforcement). The assembled CAD model with corrugated shape reinforcement is shown in Fig 2. To study the effect of shape of reinforcement over the flexural properties of AM multi materials, reinforcement in flat shape and corrugated shape as shown in Fig 3. were modelled which were lateral assembled into matrix part for fabrication. For description here after flat shape and corrugated shape reinforcement were described as pattern 1 and pattern 2.

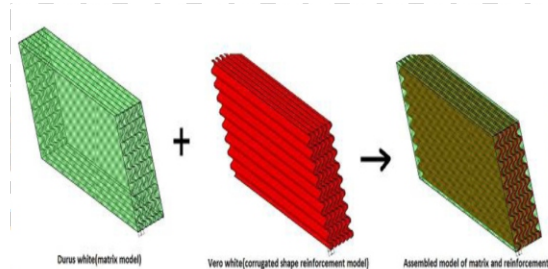

Fig 2. Flowchart for modeling composite material for 3DP process.

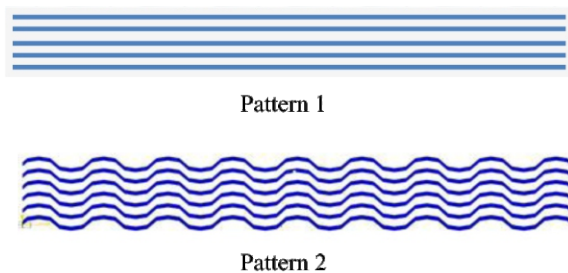

Fig 3. (i) Pattern 1 with flat shape reinforcement and (ii) Pattern 2 with corrugated shape reinforcement

III. EXPERIMENTATION

A. Methods

Among various AM process, Polyjet 3DP technique has been selected for fabrication for polymer based composite material. Polyjet 3DP works under the mechanism where droplets of photo curable polymer resin were deposited through nozzle head as shown in Figure. 4, whereas set of white colour nozzle will deliver one type of polymer material and set of black colour will deliver another type of polymer material. So with this construction two polymer materials were deposited either within a layer with different materials or layer by layer with a thickness of about 30 μm . These thin layers of photo curable polymer resin deposited were cured by UV light. In addition polymer resins can be deposited with differing ratios which results in complex shape polymer parts with different mechanical properties can

be fabricated. The schematic diagram of polyjet 3DP is shown in Fig 4.

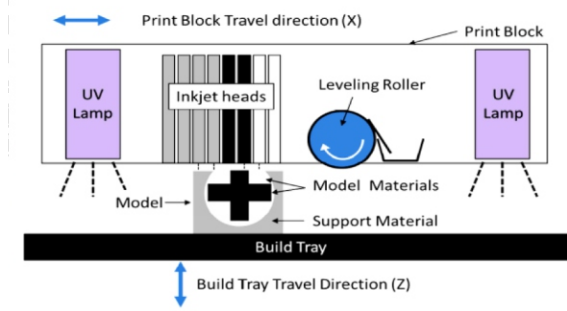

Fig 4. Schematic representation of Polyjet 3DP head assembly block. [10]

B. Materials

As mentioned earlier, the materials used in polyjet 3DP technique are photopolymers, which are polymeric materials sensitive to light, meaning they are solidified under the action of UV light. Polyjet 3DP can process wide range of polymer materials with different properties to provide greater strength, stiffness, heat deflection, etc. This wide range of polymer includes high strength ABS, flexible polypropylene, and rubber like elastomers. Exact details of these materials are undisclosed but they were named under the trade mark name (e.g. .Vero white, Durus white, tango etc.) provided by the machine supplier. Table2. Summarize properties of polyjet 3DP polymer materials considered for fabrication of composite structure.

TABLE I
PROPERTIES OF POLYMER MATERIAL CONSIDERED FOR FABRICATION OF COMPOSITES.

Sl. No	Properties	Materials	
		Vero White (Reinforcement)	Durus White (Matrix)
1	Tensile strength	50 MPa	21 Mpa
2	Modulus of Elasticity	2495 MPa	1136 Mpa
3	Elongation at break	20 %	44 %
4	Flexural strength	75 Mpa	33 Mpa
5	Izod Notched Impact	24 J/m	44 J/m

C. Flexural Test

Flexural strength measurements were conducted on AM multi material structure (with reinforcement (pattern 1 and pattern 2) and without reinforcement) as per ASTM D790 standard using three point bend fixture (as shown in figure 5.b) on an Instron-8322 testing machine at a normal ambient temperature with a cross head speed of 5mm/min. The dimensions of the specimen according to ASTM D790 standard is shown in Fig.5.(a)

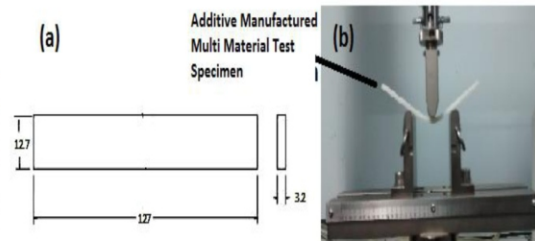

Fig 5. (a) Dimensions of ASTM D790 flexural test specimen [12], (b) three point bending fixture for flexural test

IV. RESULTS AND DISCUSSION

The flexural properties of AM multi material specimen as a function of flat shape and corrugated shape reinforcement are summarized in Table 2. From the experimentation it was observed that the maximum flexural load withstanding capacity of specimen and flexural modulus of multi-material corrugated shape is almost 5.74 and 0.53 times higher than polymer specimen without corrugated shape, however introducing flat shape reinforcement has resulted in reduction of flexural properties than matrix material. This indicates that the increase in stiffness is negligible and the increase in strength is higher than that of the flat shaped structure. From the experimentation it was observed that the maximum flexural load withstanding capacity of specimen and flexural modulus of without reinforcement shape is almost 2.72 and 1.02 times higher than polymer specimen multi-material corrugated shape. Again the comparison between the flat shape reinforcement and without reinforcement were observed that the maximum flexural load withstanding capacity and flexural modulus of multi-material corrugated shape is almost 0.81 times higher than that of specimen without reinforcement shape and 0.32 times lower than that of specimen without reinforcement. In this experimentation stiffness is increased but the strength is decreased.

Table II
FLEXURAL PROPERTIES OF 3D PRINTED POLYMER BASED
COMPOSITE MATERIAL

Sl.No	Properties	With reinforcement		Without reinforcement
		Pattern 1 Flat shape	Pattern 2 Corrugated shape	Specimen with matrix material alone
1	Maximum load (N)	14.29	96.41	25.89
2	Flexural extension at maximum load	3.88	8.35	10.86
3	Flexural stress (MPa)	4.85	24.59	9.80
4	Flexural Modulus (MPa)	399.8	613.5	302.29

Flexural properties of flat shape reinforcement was poor due to de-lamination of layer under the bending load which is observable in six number of sharp peaks in stress-strain behavior of AM multi material structure under flexural loading as shown in fig 6. The stress-strain relationship for flat shaped reinforcement, corrugated shaped reinforcement and without reinforcement have been discussed below and the successive stress-strain graph is also plotted.

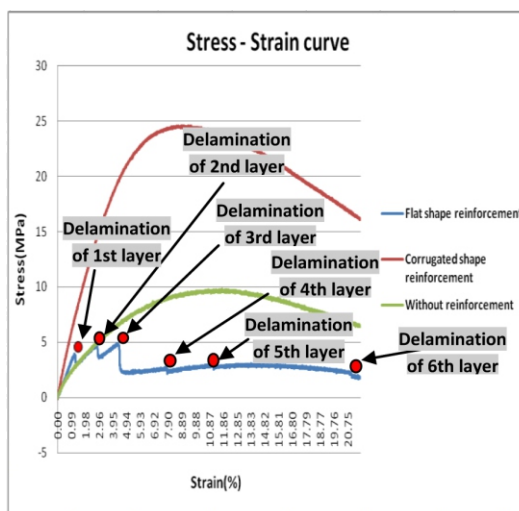

Fig 6. Stress -Strain behavior of AM structure with flat shape reinforcement, corrugated shape reinforcement and without reinforcement.

V. CONCLUSION

The work presented in this article explores the new and innovative manufacturing method (Additive manufacturing) for fabrication of multi materials with complex shape (corrugated structure) reinforcement. The following conclusions were drawn based upon the modelling, fabrication and flexural testing of 3D printed composite material.

1. With this automated 3DP process, limitations of conventional composite manufacturing techniques such as maintaining uniform distance between reinforcement with control geometric dimensions is completely avoided.
2. Flexural strength and flexural modulus of AM multi material with corrugated shape reinforcement were 2.72 times and 1.02 times higher than AM structure without reinforcement.
3. Enhancement in flexural modulus as well as flexural strength shows an excellent bonding between the materials used in fabrication of multi material structure.
4. Flat shape reinforcement has resulted in decrement of flexural properties due to de-lamination of matrix and reinforcement layers in AM structure.

ACKNOWLEDGEMENT

The work described in this paper was supported by Grants (INSPIRE Fellowship Reg. No.IF120710) from the Department of Science and Technology, Ministry of Science and Technology, Government of India. The financial contribution is gratefully acknowledged. We would also acknowledge Department of Textile Engineering, A.C Tech and Anna University Chennai for providing testing facility.

REFERENCES

- [1] D. Dutta, F.B. Prinz, D. Rosen, and L. Weiss, "Layered Manufacturing: Current Status and Future Trends," *J. Comput. Inform. Sci. in Eng.*, (ASME), Vol 1_Issue 1, pp. 60-71, 2001.
- [2] ASTM. "ASTM F2792-10 Standard Terminology for Additive Manufacturing Technologies." American Society for Testing and Materials (ASTM).
- [3] M. Sugavaneswaren and G. Arumaikkannu. "Modelling for randomly oriented multi material additive manufacturing component and its fabrication", *Materials & design*, vol 54, pp.779-785, 2014.
- [4] S. Kumar and J.P. Kruth. "Composites by Rapid Prototyping Technology", *Materials and Design*, Vol.31, JP 2010.
- [5] Y. Liu and I. Gibson, "A framework for development of a fiber-composite, curved FDM system". *Proceedings of the International Conference on Manufacturing Automation, ICMA '07*, 28-30 May, Singapore, pp. 93-102, 2007.
- [6] I. Gibson, D.W. Rosen and B. Stucker "Additive Manufacturing Methodologies: Rapid Prototyping to Direct Digital Manufacturing", Springer 2010.

-
- [7] G. Brett Compton and A. Jennifer Lewis. "3D-Printing of Lightweight Cellular Composites", 2014.
- [8] J. Munguia, S. Akande and K.W. Dalgarno, "Compliant flexural behaviour in laser sintered nylon structures: Experimental test and Finite Element Analysis – correlation"54:652-659, 2014.
- [9] P.M. Pandey, N.V. Reddy and S.G. Dhande, "*Slicing Procedures in Layered Manufacturing: A Review*", Rapid Prototyping Journal, Vol 9_Issue 5, pp. 274-288, 2003.
- [10] A. M. Elliott, O. S. Ivanova, C.B. Williams and T.A. Campbell, "An investigation of the effects of quantum dot nanoparticles on photopolymer resin for use in polyjet direct 3d printing".
- [11] ASTM Standard D790-02. "Standard test Method for Flexural properties of unreinforced and reinforced plastics and electrical insulating materials", ASTM West Conshohocken, PA , 2002.

Development of low cost surface finishing equipment for surface finish enhancement in 3D Printed Parts

Sreekanth N V¹, Arjun C C², Dr. K Guruprasad³

^{1,2}Assistant Professor, Department of Mechanical Engineering, BMS College of Engineering, Bengaluru, Karnataka, India

³Professor & Dean, Department of Mechanical Engineering, BMS College of Engineering, Bengaluru, Karnataka, India

Abstract

A major drawback in the fused filament fabrication technique is that it does not provide a great surface finish. This can primarily be attributed to the effect of “staircase” during the printing where the resulted surface looks similar to a topographic map. This problem can be rectified by varying the process parameters viz., layer thickness, raster width, air gap, raster angle etc. which are all methods in the pre-production stage. However, in consideration of the mentioned parameters, it is also possible to enhance the surface finish by using post-production techniques as well such as painting, chemical treatment and sand blasting. In this work, an attempt is made to develop low cost sand blasting equipment which will aid in enhancing the surface finish of the 3D printed components.

1. Introduction

The main components of the abrasive blasting system are the fluid compressor, the blast cabinet, the abrasive feed system, the blast gun. There are two types of the feed system namely, the siphon feed system where the blast gun creates vacuum which takes in the abrasive and injects it onto the specimen surface and the gravity feed system where the abrasive is fed with the aid of the gravitational force. In the present research, the authors have made use of the siphon feed system of the blast gun.

The block diagram shown below shows the path followed by which the specimens are

finished using the abrasive blasting equipment.

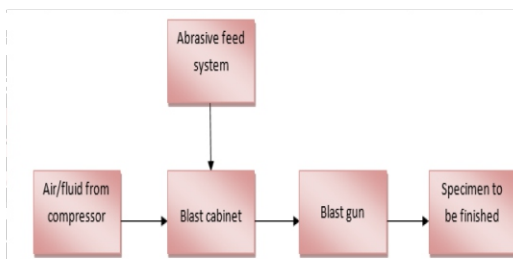

Fig 1.1: Typical sand blasting operation

As the concept of additive manufacturing is taking main stage in the frontiers of the manufacturing space, there are numerous models and theories which are being thought of in order to create better products with higher efficiencies. The method of Fused Filament Fabrication (FFF) also known as Fused Deposition Modeling (FDM) is used for the creation of the 3D printed parts in this research.^[1]

One of the major drawbacks of fused filament fabrication is the surface finish. This can be addressed by employing the following techniques:

1. Optimization of build orientation
2. Slicing strategy (layer thickness).
3. Fabrication parameters optimization
4. Post-treatment

If the first three methods are considerations which can be employed before the part is manufactured, the fourth technique includes abrasive blasting, chemical treatment and painting. In this work a product is developed in order to enhance the surface finish of

component made from the fused filament fabrication technique.^[2]

1.2 Surface Roughness Measurement

Parts produced by any manufacturing methods have surface imperfections and irregularities. Surface may have irregularities in the form of succession of hills and valleys. These irregularities are called as surface roughness or surface texture. They influence the appearance of a surface and functionality a part.

Reasons for Controlling Surface Texture:

1. For good appearance.
2. Improving the service life of a part
3. To improve the fatigue resistance
4. To reduce wearing of parts
5. To obtain dimensional accuracy of the parts
6. To reduce frictional wear and corrosion

Measurement of surface finish surfaces texture

The methods used for ensuring the surface finish can be classified broadly into two groups.

- i. Inspection by comparison.
- ii. Direct instrument measurement

i. Inspection by comparison methods:

Surface roughness is assessed by observation of the surface. These are qualitative analysis methods of the surface texture. The texture of the surface to be tested is compared with that of a specimen of known roughness value. These methods are rapid, the results are not reliable.

ii. Direct Instrument Measurement:

These are quantitative analysis methods which can determine the numerical value of the surface roughness by the use of stylus probe operations which work on electrical

principles. The output value has to be amplified and this amplified signal is used to operate the instrument.^{[3][4]}

1.3 Product Development Process

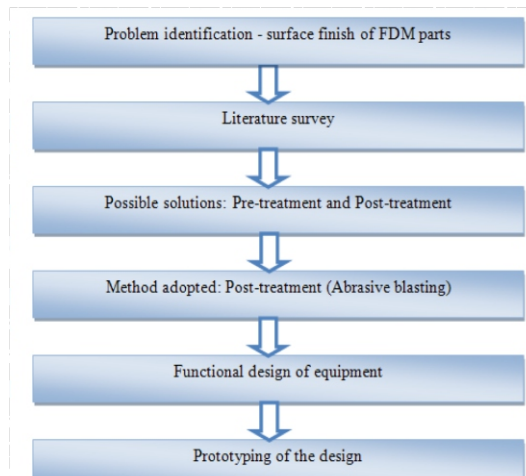

Fig 1.2: Prototype Development flowchart

2. Design of Abrasive Blasting Equipment

In this work the abrasive blasting method was chosen to improve surface finish of FFF parts. The abrasive blasting cabinet was designed (functional design) and fabricated by using sheet metal made of Mild Steel with thickness 1.6mm.

A functional design of the abrasive blasting equipment was formulated considering the average human height. The dimensions considered were in accordance with the Department of Energy (DOE) - 1140-2001 human Factors/Ergonomics, for the design for ease of maintenance.

The different views of the sand blasting equipment are shown below.

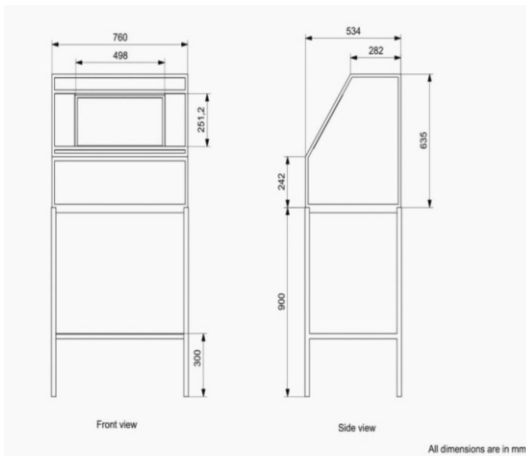

Fig 2.1: Cad Drawing of Abrasive Blasting Equipment

Figure 2.1 represents the two views of the abrasive blasting equipment with dimensions in millimeters.

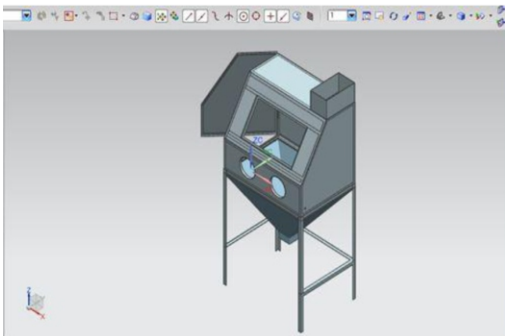

Fig 2.2: 3D Assembled model of Abrasive Blasting Equipment

Figure 2.2 represents the assembled model of the abrasive blasting equipment assembled using the commercially available 3D modeling software.

The cabinet design was accommodated for the average human being height of 175 cm and the build volume being 228x228x228mm designed aptly corresponding to the general 3D printer dimensional volume.

The details of the components are as follows:

i) *Frame*: The skeleton of the body is built using mild steel material with thickness 3mm and width 25 mm.



Fig 2.3: Cad model of the frame

ii) *Viewing glass*: A viewing glass with below mentioned dimensions was fixed to beading provided on the inclined sheet metal with dimensions 500x300x5 mm.

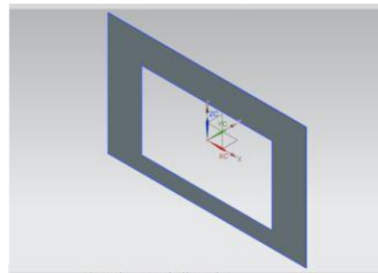

Fig 2.4: Cad model of the front panel with viewing glass

iii) *Back wall*: The back wall with dimensions 762x635x16 mm was cut and welded to the frame. Right Side wall: Base depth 534mm. Height of cabin: 635mm. Ceiling depth: 280mm with an inclined angle face: 457mm 254mm/394mm.

iv) *Glove panel*: Length of the glove panel: 762mm. Height of the glove panel: 240mm. Provisions for gloves: average human hand width is about 95mm. Hence two glove holes with diameter 150mm were made for free movement of the hands. Gloves of length 560mm were fixed to the circular

holes as average human bent arm length is 480 mm.

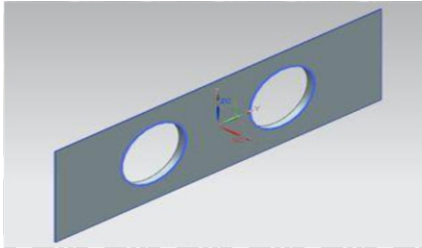

Fig 2.5: Cad model of the glove panel

v) Ceiling: Length: 760mm, Width: 280mm

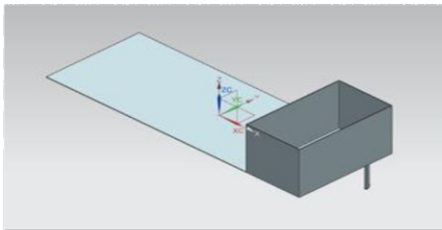

Fig 2.6: Cad model of the ceiling with abrasive reservoir compartment

vii) Abrasive reservoir compartment: It is positioned on the right corner of the ceiling. Length: 160mm, Width: 270mm, Depth: 150mm.

viii) Perforated sheet: It is welded to the bottom of the cabinet through which the sand particles exit the cabinet. Length: 160mm, Width: 130mm.

viii) Input pressure source through compressor: A multistage compressor was used to obtain the compressed air. The outlet of the compressor was connected to the blast gun via 1/2" tube. A pressure gauge was connected to this tube to measure the output pressure. Flow control valve was used to control the out flow of the pressurized air.



Fig 2.7: Multistage air-compressor in the Energy Conversion Engineering (ECE) Lab, BMSCE

ix) Abrasive feed system: The feed system which is used is a siphon feed system, where the pressurized air passing inside the blast gun creates a negative pressure /vacuum that results in suction force which pulls the abrasives towards the blast gun as shown in figure. The abrasives were stored inside the reservoir which is placed on top of the blasting cabinet.

x) Blast gun: A blast gun with nozzle diameter 2mm was used for the sand blasting operation. The initial design of the gun had a cup shaped reservoir attached to the gun i.e. the abrasive feed was through gravity. Slight alterations were made to the blast gun and was converted into a siphon feed system. The blast gun was connected to the reservoir via a 1/4" tube with the help of 3/8" BSP male (brass) and 3/8" BSP hose nipple.

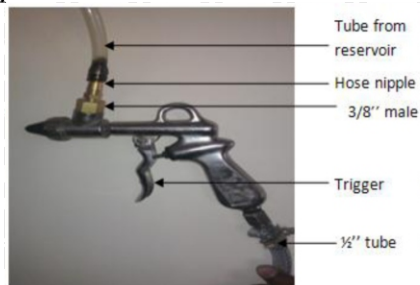

Fig 2.8: Siphon feed system

3. Prototype Development

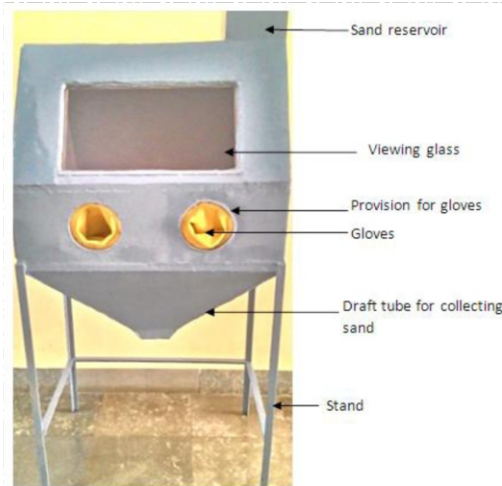

Fig 3.1: Abrasive Blasting Unit (Front)

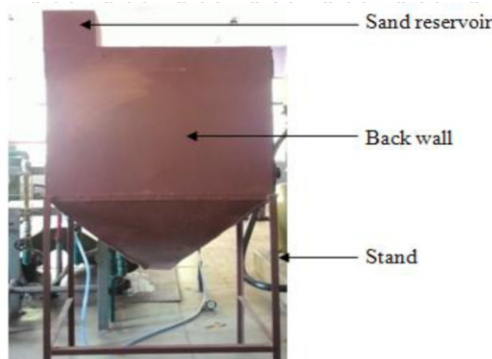

Fig3.2: Abrasive Blasting Unit (Rear)

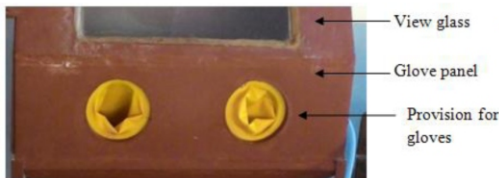

Fig3.3: Glove panel and view glass



Fig3.4: Ceiling with abrasive reservoir compartment

The prototype is developed in accordance to the considered design considerations.

4. Costing

Sl.No.	Item	Cost incurred (INR)
1.	Gun	600
2.	Hose pipe and nipple	200
3.	Pressure gauge	150
4.	Glass	150
5.	Gloves	200
6.	Clamps	100
7.	Light	250
8.	Chamber fabrication	4500
9.	Red oxide	100
10.	Paint	100
11.	Transportation	500
12.	Abrasive(SiC)	1200
	Total	8000

Table 4.1: Details of costing of abrasive sand blasting equipment

5. Conclusions

- A prototype was successfully developed as per design considerations to cater to a test specimen within the dimensions of 300x300x300 mm.
- The present prototype which runs on the siphon type feed system can work efficiently with any type of abrasive and also can be used as a painting equipment.
- The design which is in accordance to the Department of Energy (DOE) – 1140-2001 human factors/ergonomics will yield in better comfort for the worker and will aid in ease of maintenance.
- The design of equipment will facilitate in conducting tests varied pressures and volume of air.

6. References

- [1] Pandey, P.M., Reddy, N.V. and Dhande, S.G.(2003) *'Improvement of surface finish by staircase machining in fused deposition modeling'*, Journal of Materials Processing Technology, Vol. 132, pg. 323-331.
- [2] Rao, A.S., Dharap, M.A., Venkatesh, J.V.L. and Ojha, D. (2012) *'Investigation of post processing techniques to reduce the surface roughness of fused deposition modeled parts'*, International Journal Of Mechanical Engineering And Technology, Vol. 3, No. 3, pg. 531-544.
- [3] P. Vijay, P. Danaiah, K. V. D. Rajesh , *"Critical Parameters Effecting the Rapid Prototyping Surface Finish"*, Journal of Mechanical Engineering and Automation 2011; 1(1): 17-20
- [4] Sreedhar, C.Mathikumar Manikandan, *"Experimental Investigation of Surface Roughness for Fused Deposition Modeled Part with Different Angular Orientation"*, Int J Advanced Design and Manufacturing Technology, Vol. 5/ No. 3/ June – 2012; 21-27



Additive Manufacturing Society of India (AMSI)

Additive Manufacturing Society of India

"AMSI educates and promotes the latest developments and applications in Additive Manufacturing Technologies" Additive Manufacturing Society of India (AMSI) is the professional body with the objective to promote 3D printing & Additive Manufacturing Technologies. AMSI helps the design, research and development organisations, manufacturing professionals and academics in 3D Printing, Additive Manufacturing and allied technologies.

AMSI plays a major role in promoting 3D printing & Additive Manufacturing technologies and has great network and MOU's with global additive manufacturing organisations.

Additive Manufacturing Society of India Membership

Membership Benefits

- Networking and interaction opportunities with global Additive Manufacturing experts
- Provision with ample business opportunities and to enhance business relationships for industries
- Free Subscription to AMSI journals & News Letter
- Membership Certificate entitlement to use 'M AMSI'
- Provision for members to update their knowledge through workshops, conferences, publications and online courses

#42, BSK 3rd Stage, 3rd Phase, 3rd Block, 9th Cross, Bangalore- 560 085, INDIA

Tel Fax : +91 80 26729437 / 32422663

Mobile : +91 94837 17449

E-mail : contact@amsi.org.in, Website : www.amsi.org.in

Social Media Networks:



Additive Manufacturing Journal

The international journal for research & development on Additive Manufacturing & 3D Printing Technologies

Contents

- 01 Access this journal online
- 02 **Editorial**
- 03 **Mathematical Modeling for Surface Hardness in FDM Assisted Vacuum Moulding of Al-SiC Metal Matrix Composite**
Sanjeev Kumar, Rupinder Singh
- 11 **Novel Image-Based Lattice Generation Techniques**
Yash Agarwal, David Raymont
- 14 **3D Finite Element Analysis of Selective Laser Melting Process**
Kurian Antony
- 18 **Effective and efficient additive manufacturing ecosystems**
Aniruddha Srinath, Saurabh Dubey
- 24 **Reverse Engineering & 3d Printing of Medical, A&D Components**
Ravi Katukam
- 28 **Influence of Reinforcement Shape on Flexural Properties of Additive Manufactured Multi Material Polymer Structure**
Vijayanand. R, Sugavaneswaran. M, Arumaikkannu. G
- 33 **Development of low cost surface finishing equipment for surface finish enhancement in 3D Printed Parts**
Sreekanth N V, Arjun C C, Dr. K Guruprasad

